



IBS - Dark Matter Axion Group (DMAG)
Daejeon, South Korea



Creation Hall, KAIST Munji Campus



※ IBS-DMAG is the successor of IBS-CAPP

DMAG-8T: Axion Search with a Widely Tunable HTS Cavity via Indium-Soldering

Jiwon Lee

(on behalf of DMAG-8T)

Table of Contents

1. Introduction & Motivation
2. HTS Cavity Fabrication (via Indium-Soldering)
3. Experimental Setup: DMAG-8T
4. DAQ Workflow & Preliminary Results
5. Summary & Future Roadmap



Introduction: Axion

➤ Axion

The axion is a leading **dark matter candidate** that dynamically resolves the **Strong CP problem**.

Strong CP problem solution

$$\mathcal{L} \supset \bar{\theta} \frac{g_s^2}{32\pi^2} G_{\mu\nu}^a \tilde{G}^{a\mu\nu}$$

Theory: $\bar{\theta} \sim \mathcal{O}(1)$
 Exp (nEDM): $\bar{\theta} < 10^{-10}$

Discrepancy

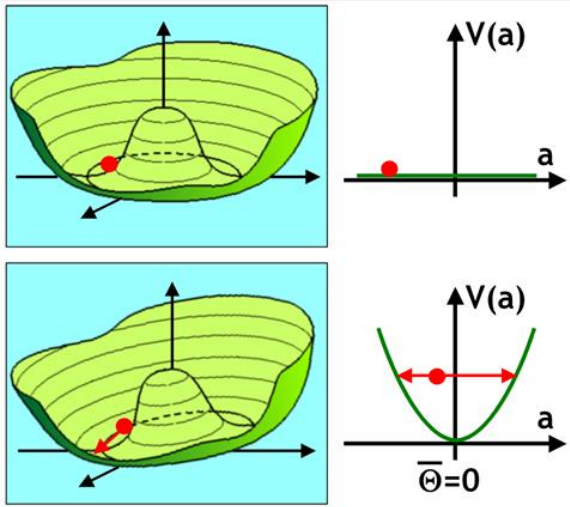

Frank Wilczek

Peccei-Quinn mechanism (1977)

<https://wwwth.mpp.mpg.de/members/raffelt/Vorlesungen/WS2009/notes/notes10.pdf>

Dark matter candidate

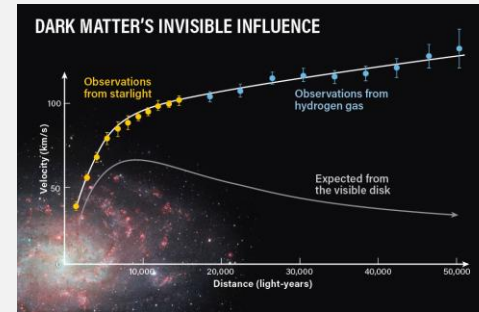

Observational evidence

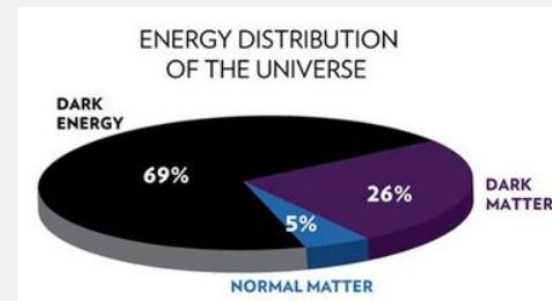

<https://www.bizhankook.com/bk/article/23838>

Introduction: Axion Haloscope

➤ Cavity Axion Haloscope

Invented by Pierre Sikivie in 1983.

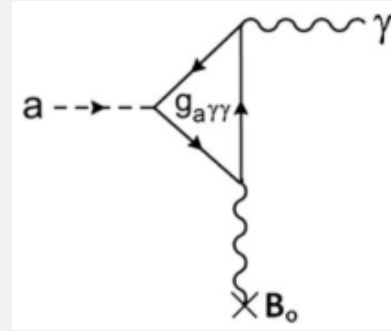
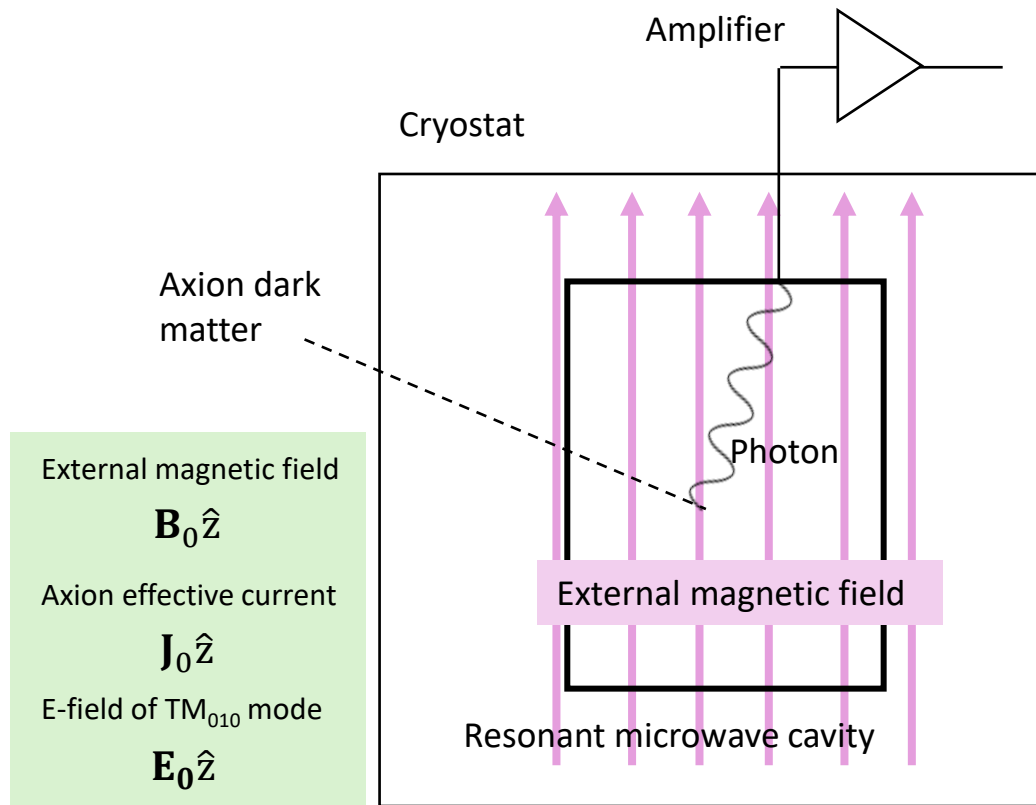

Axion-photon interaction

$$\mathcal{L} \supset g_{a\gamma\gamma} a \mathbf{E} \cdot \mathbf{B}$$

The axion field couples to the electric and magnetic fields.

Modified Ampere's Law

$$\nabla \times \mathbf{B} - \frac{\partial \mathbf{E}}{\partial t} = -g_{a\gamma\gamma} \mathbf{B}_0 \frac{\partial a}{\partial t}$$

Axion-induced effective current density (J_a)

$$J_a = -g_{a\gamma\gamma} B_0 \frac{\partial a}{\partial t}$$

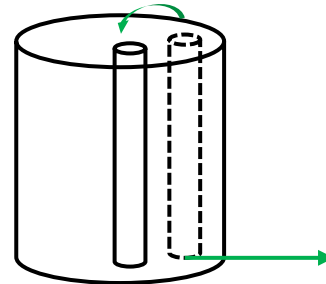

When $f_{axion} = f_{cavity}$

→ resonant conversions of axions to photons

Unknown mass

→ Frequency tuning is essential.

Dielectric or metal rod

$$f_{axion} = \frac{m_{axion} c^2}{h}$$

Motivation: Why HTS Cavity in High B-field?

➤ Exclusion limit

Extensive global efforts, including ADMX, DMAG, and HAYSTAC, are underway to probe the vast axion parameter space.

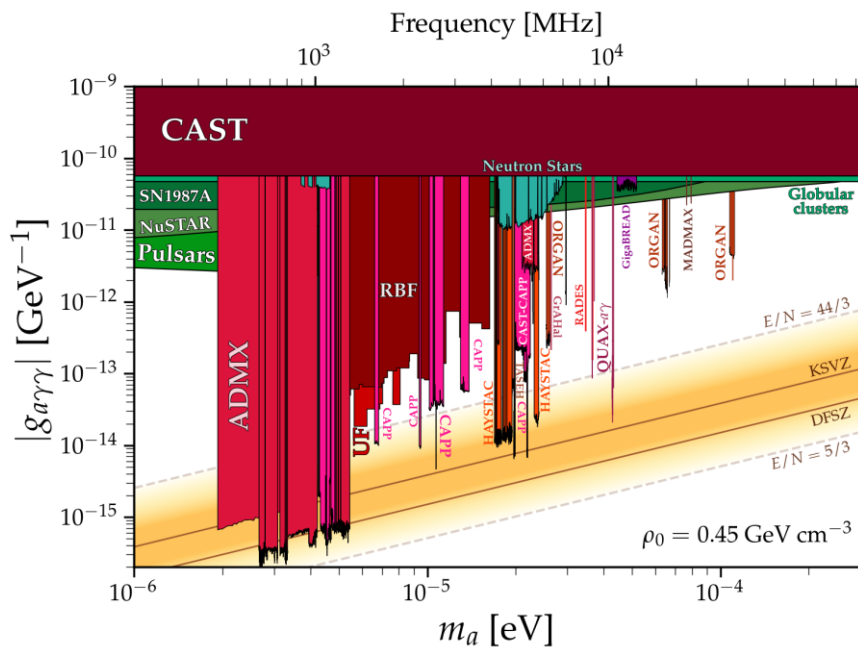

Axion conversion power

$$P_{a\gamma\gamma} = g_{a\gamma\gamma}^2 \frac{\rho_a}{m_a} B^2 V C \frac{\beta}{1 + \beta} \frac{Q_l Q_a}{Q_l + Q_a}$$

Scan rate

$$\frac{df}{dt} \propto \frac{B^4 V^2 C^2}{T_{sys}^2} Q_l Q_a$$

$g_{a\gamma\gamma}$: Axion photon coupling
 ρ_a : Axion density in the local dark-matter halo
 B : Externally applied B-field
 V : Cavity volume
 C : Cavity form factor
 Q_l : Loaded Cavity Q-factor
 Q_a : Axion Q-factor
 β : antenna coupling coefficient
 T_{sys} : system noise temperature

To improve the scan rate,

Magnetic field B^4

High cost

Cavity Volume V^2

Predetermined by commercially available SC magnets

Cavity form factor C^2

By utilizing the TM_{010} mode ($C \sim 0.69$)

System Noise Temperature T_{sys}^2

Josephson Parametric Amplifiers (JPA)

Near quantum-limited amplifier

$$T_{sys} = T_1 + \frac{T_2}{G_1} + \dots \text{ (Friis' formula)}$$

Loaded cavity Q-factor Q_l

Copper: Limited by the anomalous skin effect at cryogenic temperatures.

LTS: Vulnerable to High B-field

HTS (EuBCO): Maintains high Q-factor in multi-tesla fields

Symmetry Breaking & Indium-Soldering Technique

➤ Previous HTS cavities

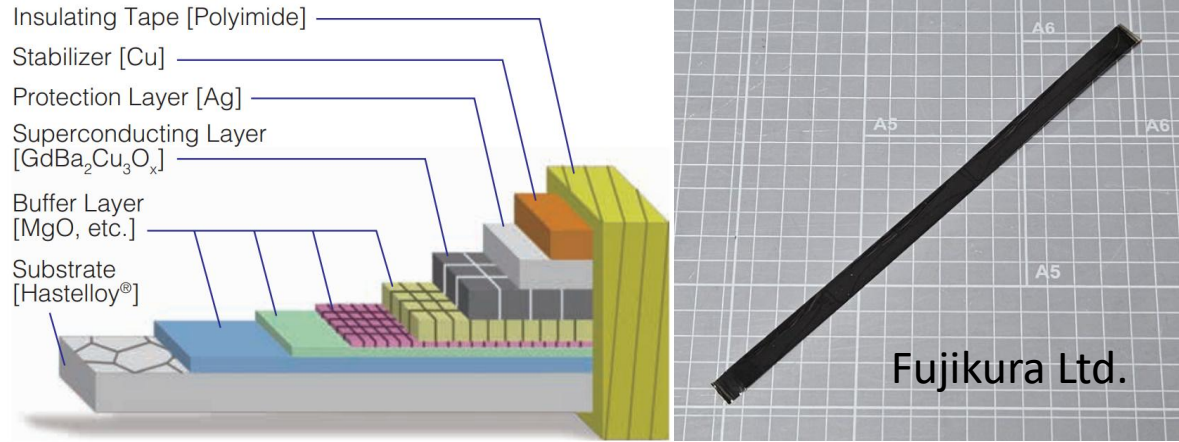

Commercially available HTS tapes

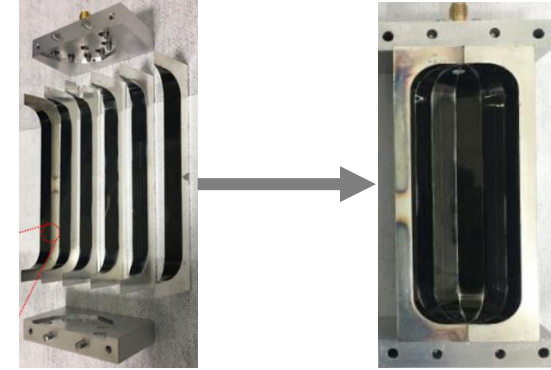

Even achieved $Q > 1M$
 Vertical gaps that are not electrically blocked
 Incompatibility of Rotating Tuning Rods

➤ Development of Indium Soldering Technology

1. Flat-sheet method

Welding seams (high-loss region)

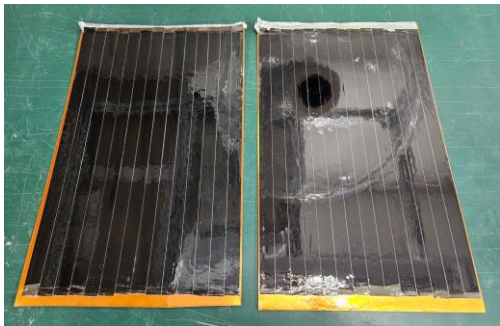

Limitations

Structure limit: restricted to thin OFHC sheet (< 0.3 mm) → Weak **mechanical strength**

RF performance limit: Longitudinal welding seams cause higher surface resistance (R_s)

2. Pipe-soldering method

Recently Developed

Seamless surface

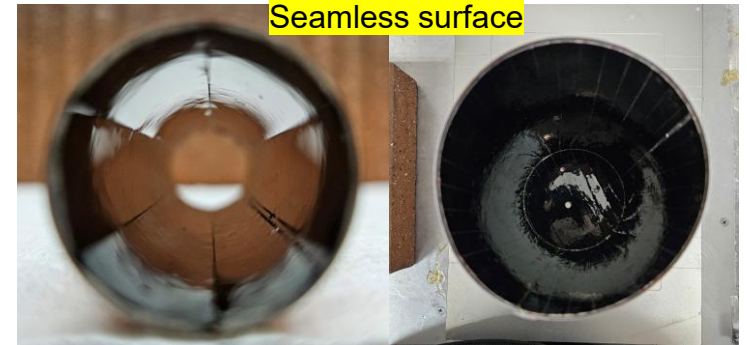

GrAHal cavity

DMAG-8T cavity

Bending + laser welding

HTS cavity for DMAG-8T

Details to follow on the next slides.

➤ Design optimization via COMSOL

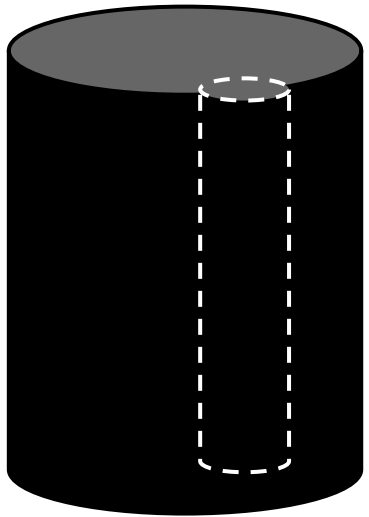

Cavity
D103mm, H220mm
Tuning rod
※ tuning radius: 8 mm

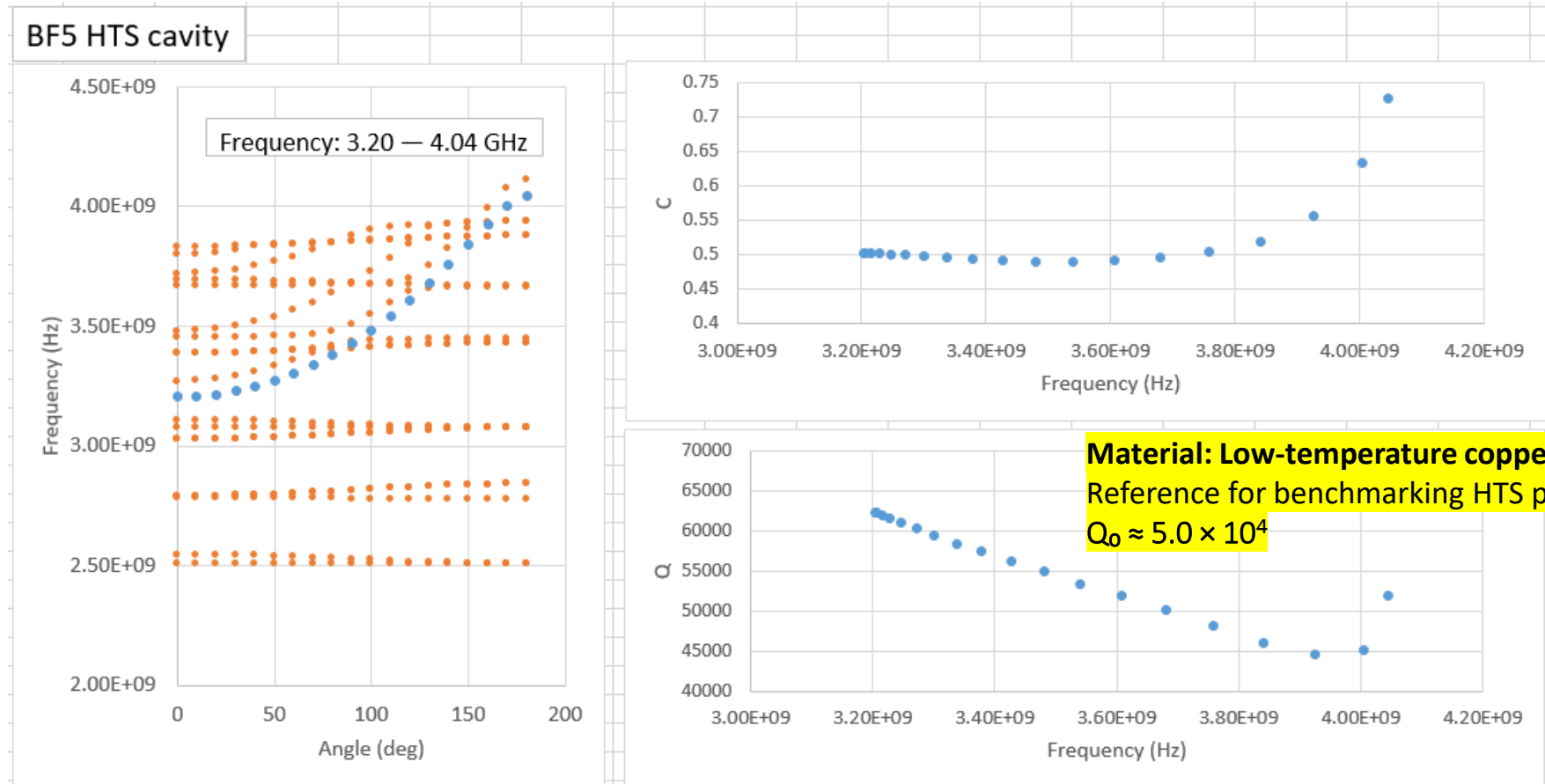

HTS cavity for DMAG-8T

Details to follow on the next slides.

- Measure performance: Mode Map & Q-factor

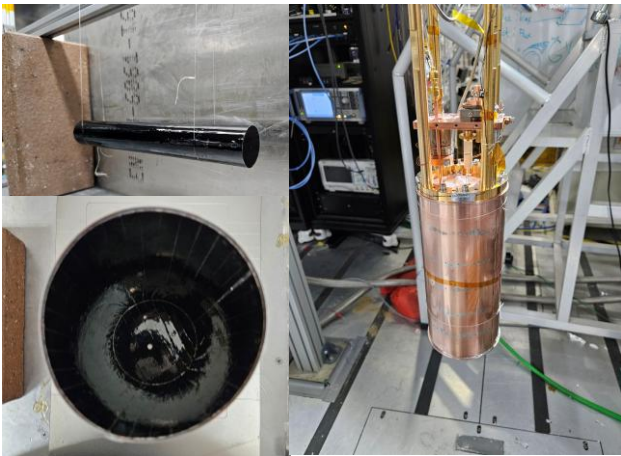
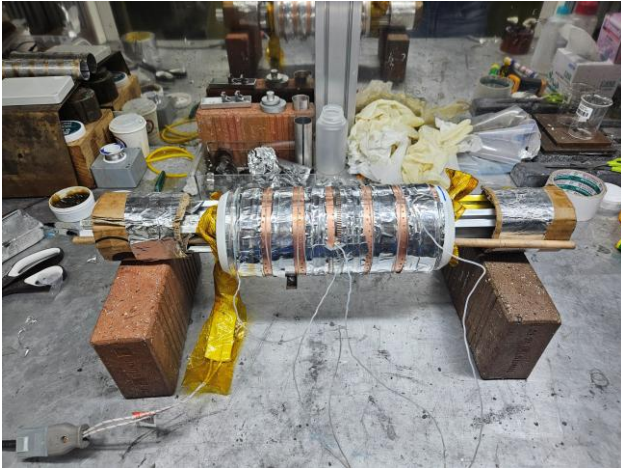

$$Q_0 \approx 2.0 \times 10^5 \text{ at } 50 \text{ mK, } 8 \text{ T}$$

A four-fold enhancement compared to the Cu cavity

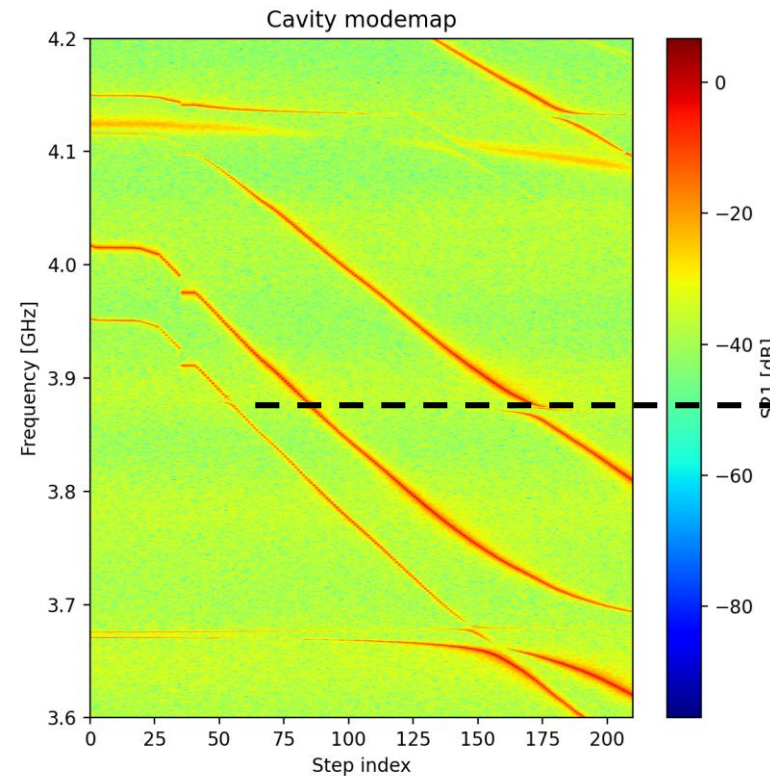

Axion search region: 3.7 – 4.0 GHz
Mode crossing region (~ 3.88 GHz)
excluded from analysis

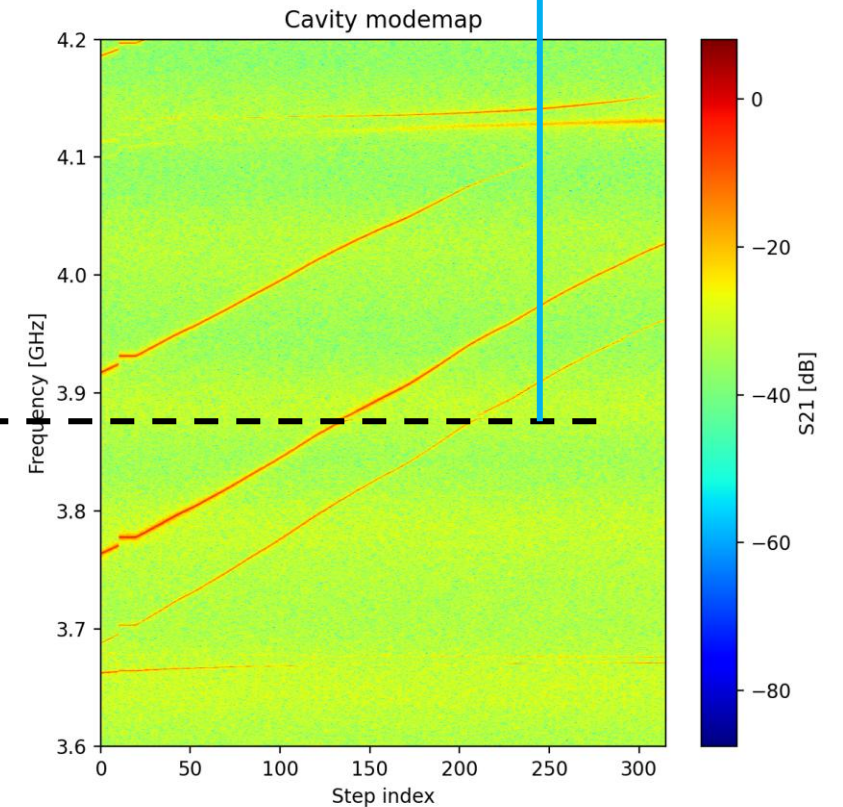

Experimental Setup: DMAG-8T

12cm bore magnet

- Bluefors dilution refrigerator LD400 & AMI 8T

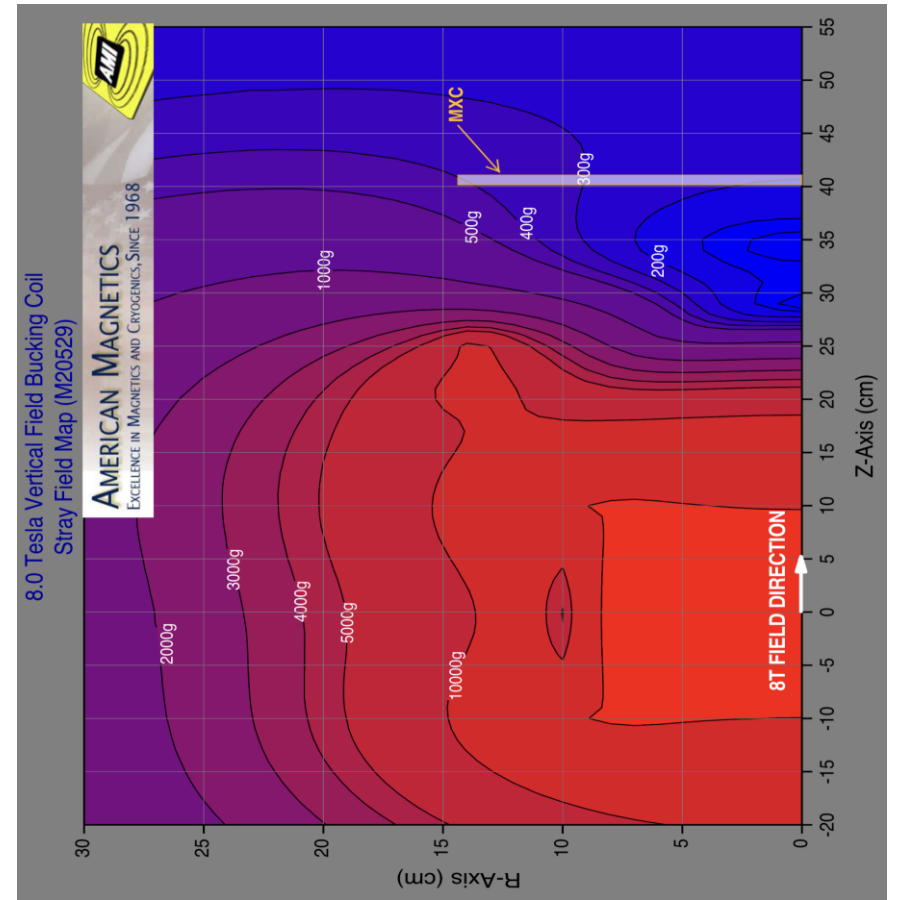
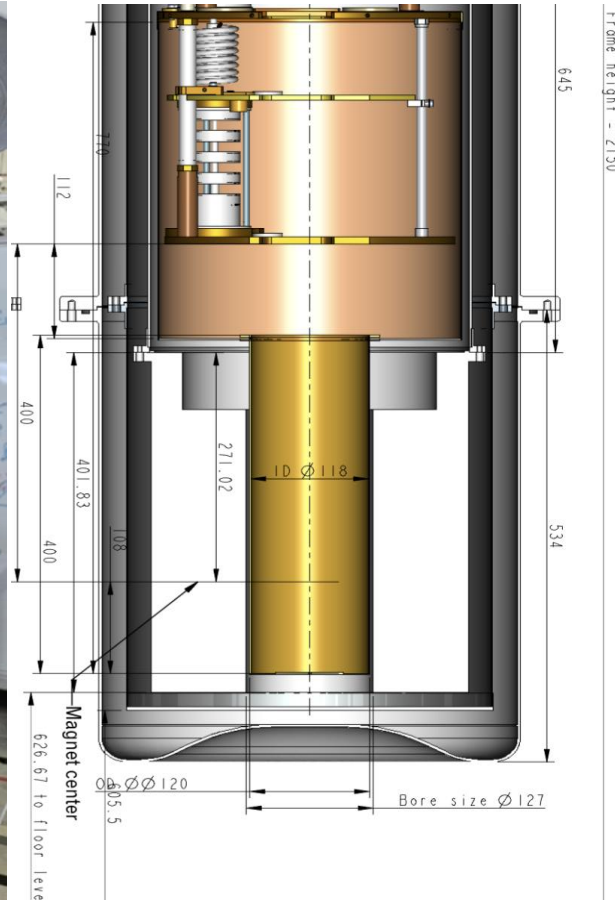
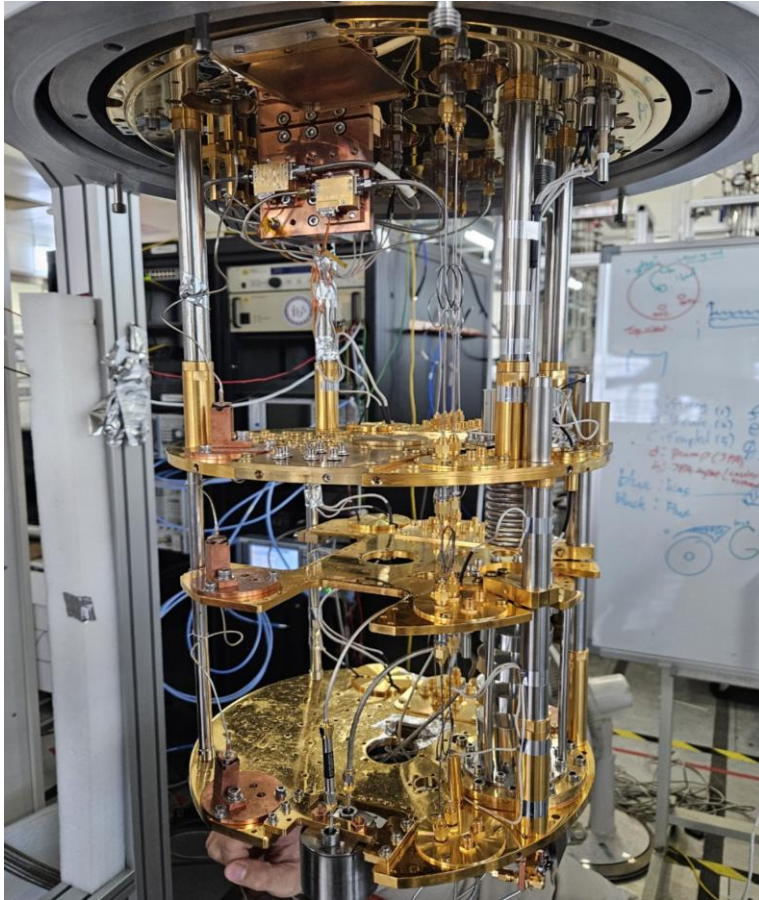

It allows us to perform sub-Kelvin measurements in a high B-field environment.

Experimental Setup: DMAG-8T

➤ RF chain

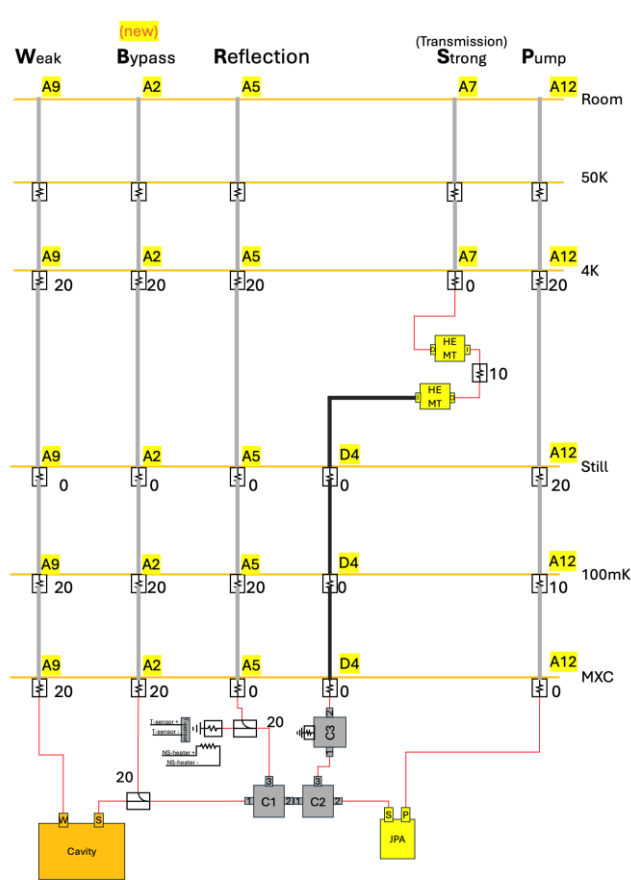

Inside Cryostat

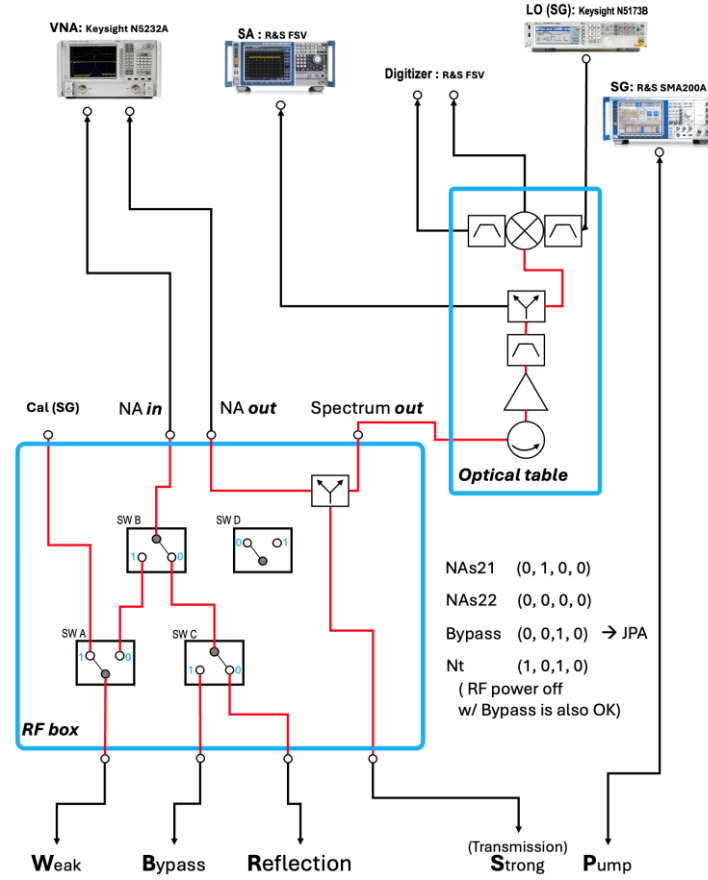

Outside Cryostat

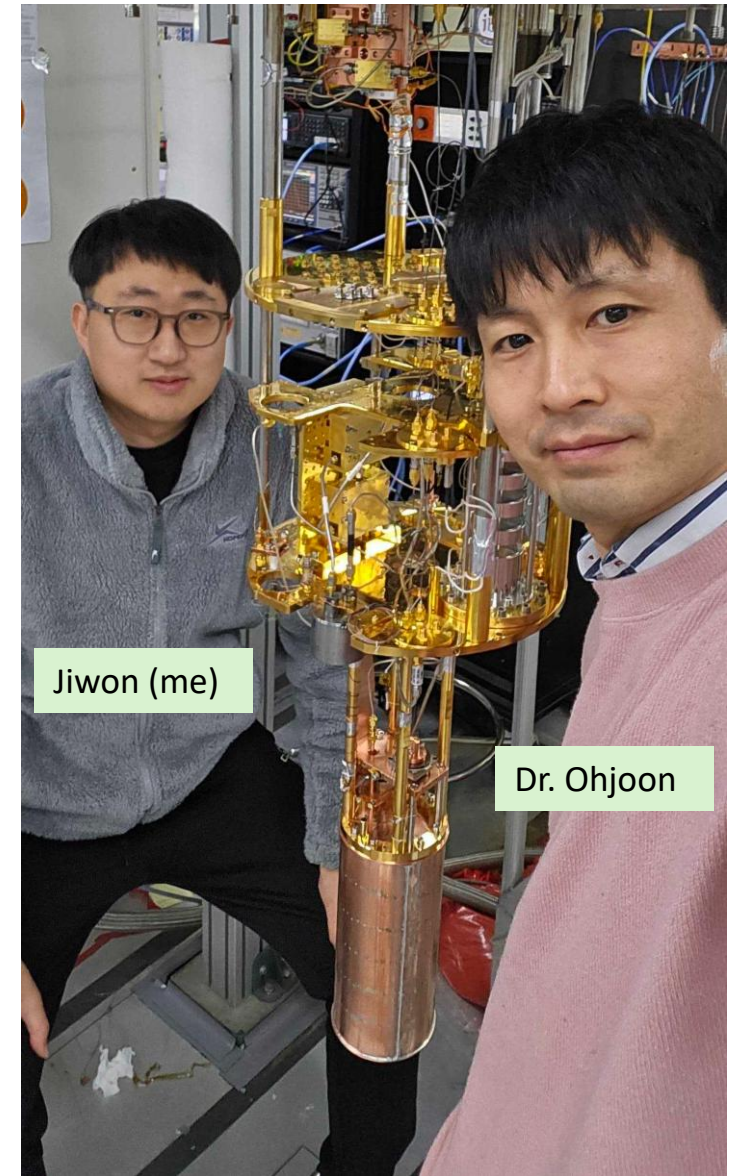

Experimental Setup: DMAG-8T

➤ Josephson parametric amplifier (JPA)

Int'l collaboration w/ Nakamura's group

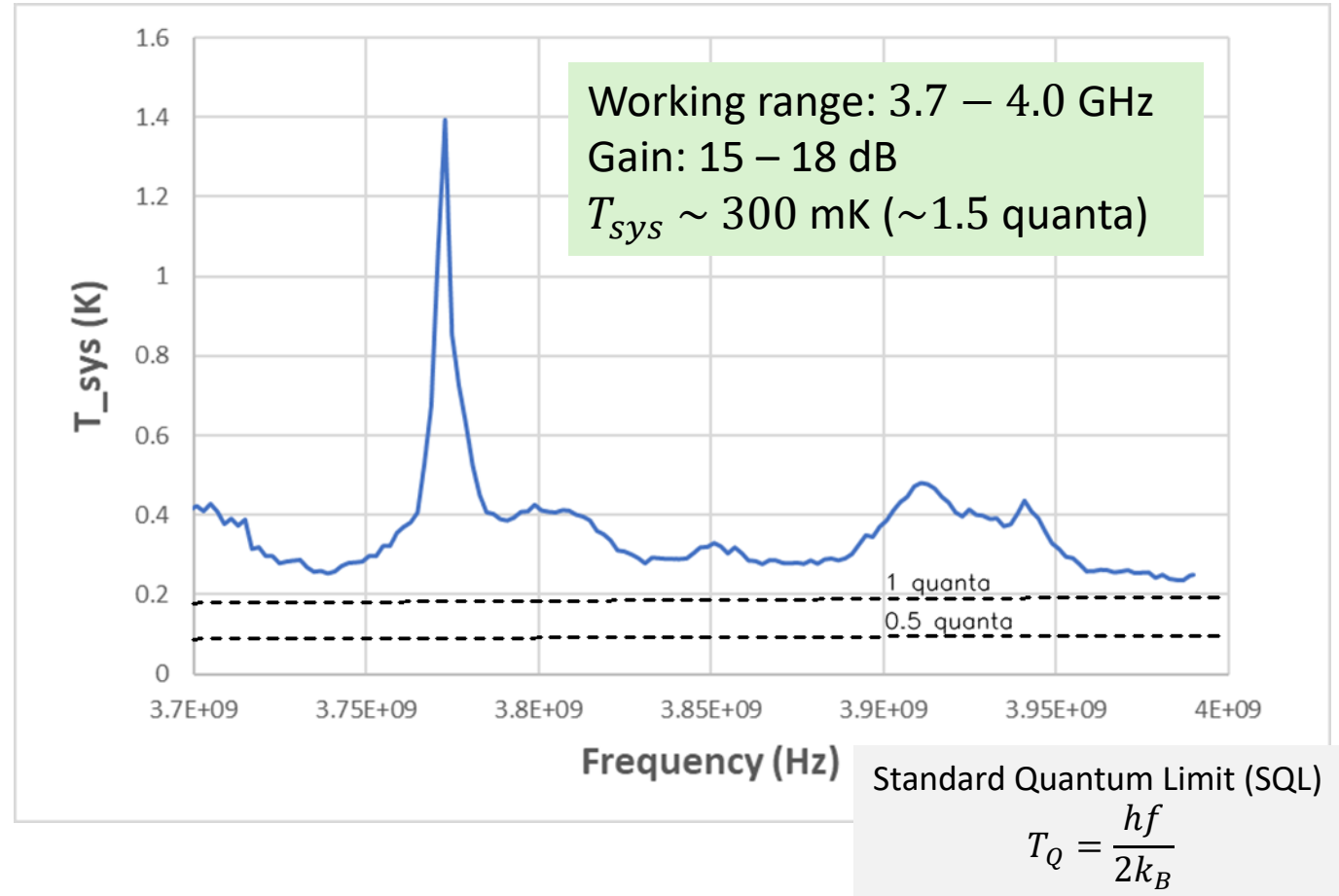
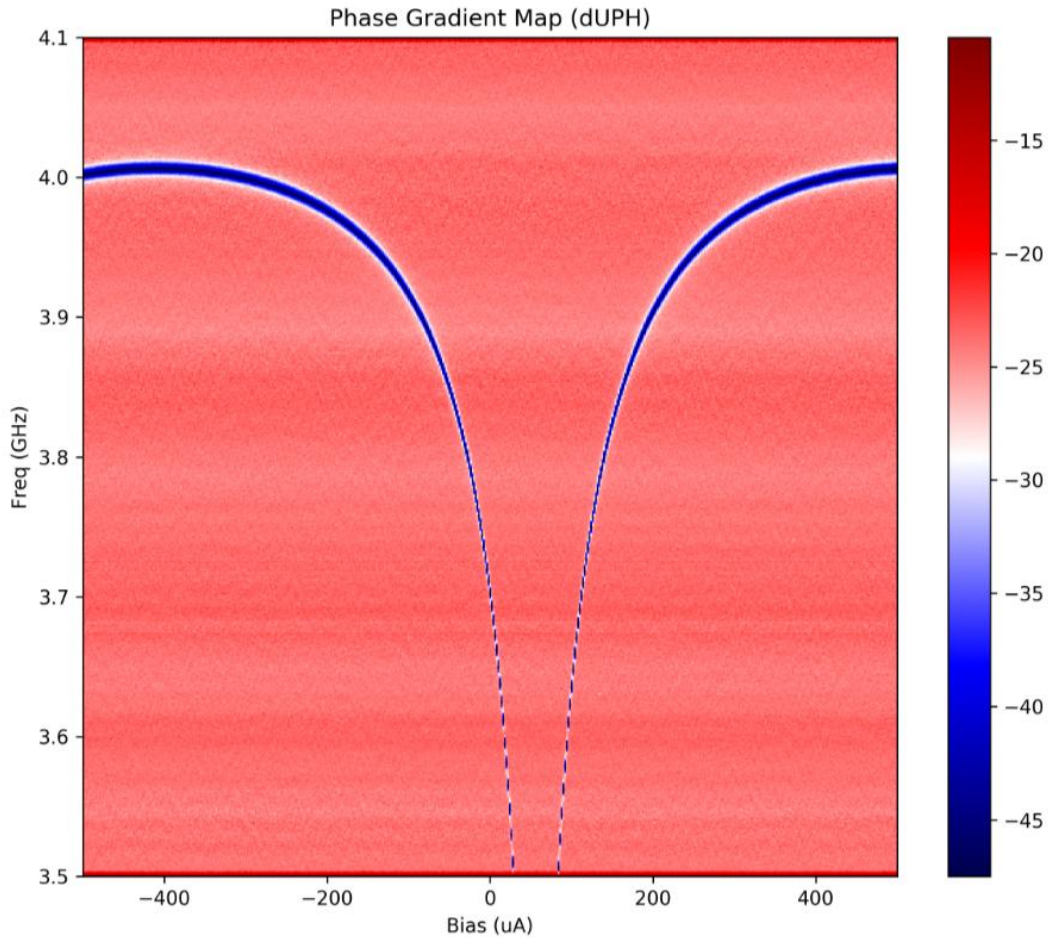

Estimated Power & Speed

```

=====
REPRESENTATIVE PARAMETERS FOR SENSITIVITY CALCULATION
=====
[A. Physics & Environment]
> Target Frequency (nu_a) : 3.8500 GHz
> Magnetic Field (B_avg) : 7.20 Tesla
> Cavity Volume (V_c) : 1.60 Liters
> Form Factor (G_form) : 0.69
> DM Density (rho_a) : 0.45 GeV/cm^3

[B. System & Operation]
> System Noise (T_sys) : 0.33 Kelvin
> Unloaded Q (Q0) : 200000
> Coupling (beta) : 2.50 (Over-coupled)
> Loaded Q (QL) : 57143
> Cavity BW (Delta_nu_c) : 67.38 kHz
> Tuning Step Size : 20.00 kHz

[C. Efficiency & Target]
> Target SNR (sigma) : 5.0
> Time Efficiency (zeta) : 0.936
> Signal Efficiency (eta) : 0.800
> Axion Q (Qa) : 1.0e+06

-----
[CALC] Axion Conversion Power Comparison
> Method 1 (PRX Scaling Law) : 2.2754e-23 Watts
> Method 2 (JCAP First Principle): 2.2898e-23 Watts
> Difference Ratio (M1/M2) : 0.9937
> SELECTED POWER FOR ESTIMATION : Method 2
> Single Bin Power (at 100.0Hz) : 5.9475e-25 Watts

-----
[EST] Expected Scan Performance
> Overlap Factor (Z) : 0.786
> Required Time per Step : 6361.4 sec
> DAILY SCAN RATE : 0.213 MHz/day
> MONTHLY SCAN RATE : 6.404 MHz/30-days
> YEARLY SCAN RATE : 77.916 MHz/year
=====
    
```

1. Axion Conversion Power Calculation

D. Kim, J. Jeong, S. W. Youn, Y. Kim, and Y. K. Semertzidis, JCAP 03, 066 (2020).

$$P_a = g_{a\gamma\gamma}^2 B^2 \frac{\rho_a}{m_a} V_c C \frac{Q_0 \beta}{(1 + \beta)^2} \approx 2.2898 \times 10^{-23} \text{ W}$$

2. Scan Rate Calculation

$$\frac{df}{dt} = \frac{\Delta\nu_{\text{step}} \cdot Z}{t_{\text{step}}}$$

Z: overlap factor
 ζ: time efficiency
 η: signal efficiency

$$Z = \frac{1}{F} \sum_{k=-100}^{100} \frac{1}{(1 + (2k/F)^2)^2}, \quad \text{where } F = \frac{\Delta\nu_{\text{cav}}}{\Delta\nu_{\text{step}}}$$

$$t_{\text{step}} = \frac{1}{\zeta} \cdot \left[\left(\frac{\text{SNR}_{\text{target}} \cdot k_B T_{\text{sys}}}{P_a} \right)^2 \cdot \frac{\Delta\nu_a}{\eta^2} \right]$$

$$\frac{df}{dt} \propto g_{a\gamma\gamma}^4$$

1.7 KSVZ → 1.78 MHz/day

DAQ Workflow & Status

➤ Unified & Autonomous DAQ Workflow (Measurement loop)

Step 1. Cavity tuning

1. Automated stuck tuning rod detection
2. Magnetic field ramping and precision frequency alignment

Step 2. Cavity characterization (Per Run)

1. Parameter extraction (f_0, Q_L, β)
2. Full S-parameter traces (S21, S22) recorded

✂ Temporarily detunes JPA bias during VNA sweeps

Step 3. JPA optimization (Per 5 Runs)

1. Lookup table assistance
2. Autonomous minimum T_{sys} search: re-optimizes bias and pump power to minimize T_{sys}

Step 4. Axion data acquisition

1. Digitizer acquisition: 780s
2. Parallel processing: Asynchronous background processing and storage to eliminate dead time

Step 5. Real-time monitoring & logging

1. MySQL & Grafana
2. Independent Multi-Stage Safety: Monitoring thermal stability ($T < 51.4$ mK) and hardware limits.

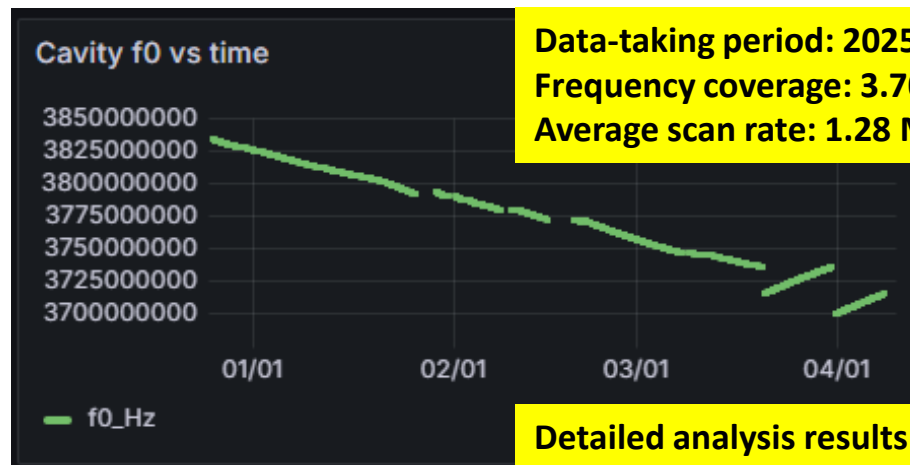

Data-taking period: 2025.12.25 17:13 – 2026.04.08 10:37
Frequency coverage: 3.700 – 3.833 GHz (Total 133 MHz)
Average scan rate: 1.28 MHz/day

Detailed analysis results are presented in the next slide.

Data Analysis Results **3.700 – 3.833 GHz (Total 133 MHz)**

➤ Baseline removal efficiency

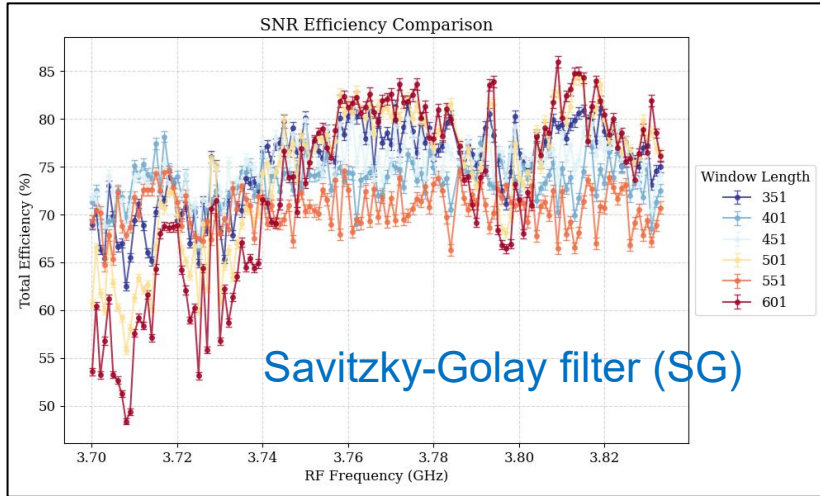

➤ Grand Spectrum

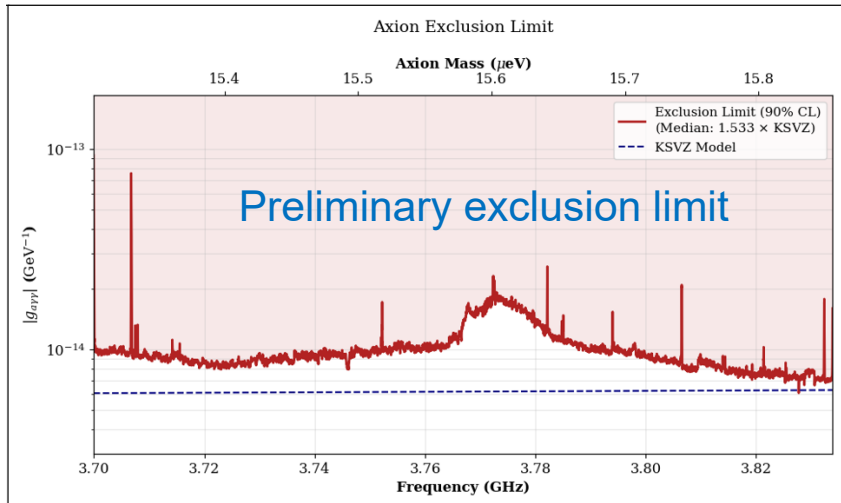
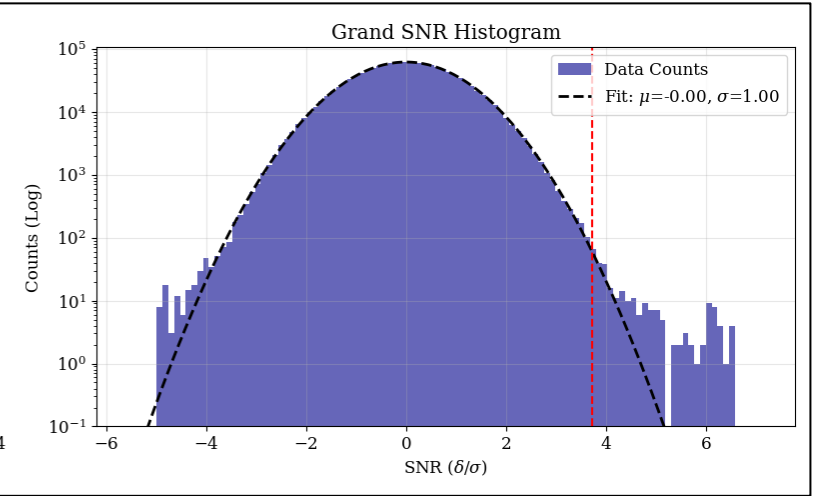
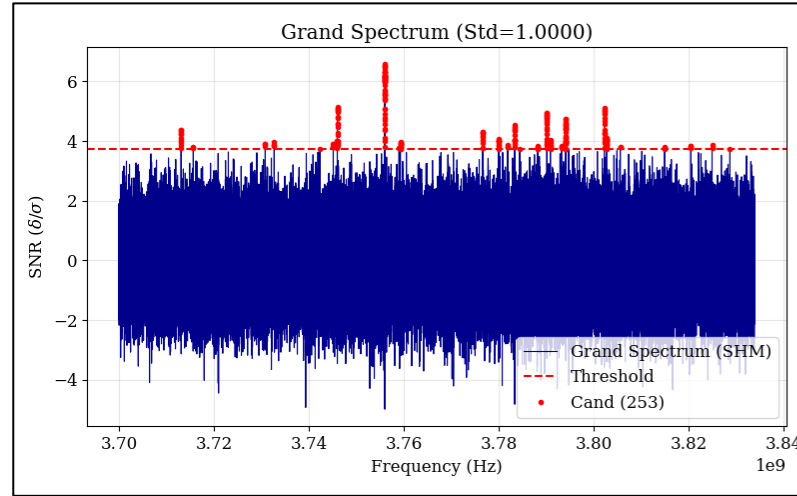

➤ Next Plans

Rescan progress:

Rescan of 28 candidates is expected to be completed by May 10, 2026.

Remaining Sweep: 3.833 – 4.000 GHz (Total 167 MHz)

Estimated completion

Current rate of 1.50 MHz/day → August 29, 2026

Summary

- **Technological Breakthrough**

- DMAG-HTS team successfully fabricated a **300 MHz tunable HTS cavity** for the DMAG-8T experiment using a novel **indium-soldering technique**.

- **High-Q Performance**

- Maintained $Q_0 \approx 2.0 \times 10^5$ at 8 T / 50 mK, representing a **four-fold improvement** over the copper cavity.

- **Data Acquisition Progress**

- Acquired a **133 MHz dataset** (3.700 – 3.833 GHz).
- Average scan rate of **1.28 MHz/day**.

- **Preliminary Results**

- Identified **28 axion candidates** for rescan with a sensitivity of **$1.5 \times \text{KSVZ}$** .

- **Future Roadmap**

- **Phase 2:** Complete the remaining a 167 MHz (**3.833 – 4.000 GHz**) sweep immediately following the current rescan process.

Thank you
