

R&D of MARQ MRPC - the TOF and muon tracker MRPCs for the J-PARC π 20 beam line

Natsuki TOMIDA
(Kyoto University, Japan)

Maxime Gouzevitch
(IP2I, France)

2024/May/22-24

2024 Joint Workshop of FKPPN and TYL/FJPPN

J-PARC $\pi 20$ beamline

New high momentum secondary beamline @ J-PARC

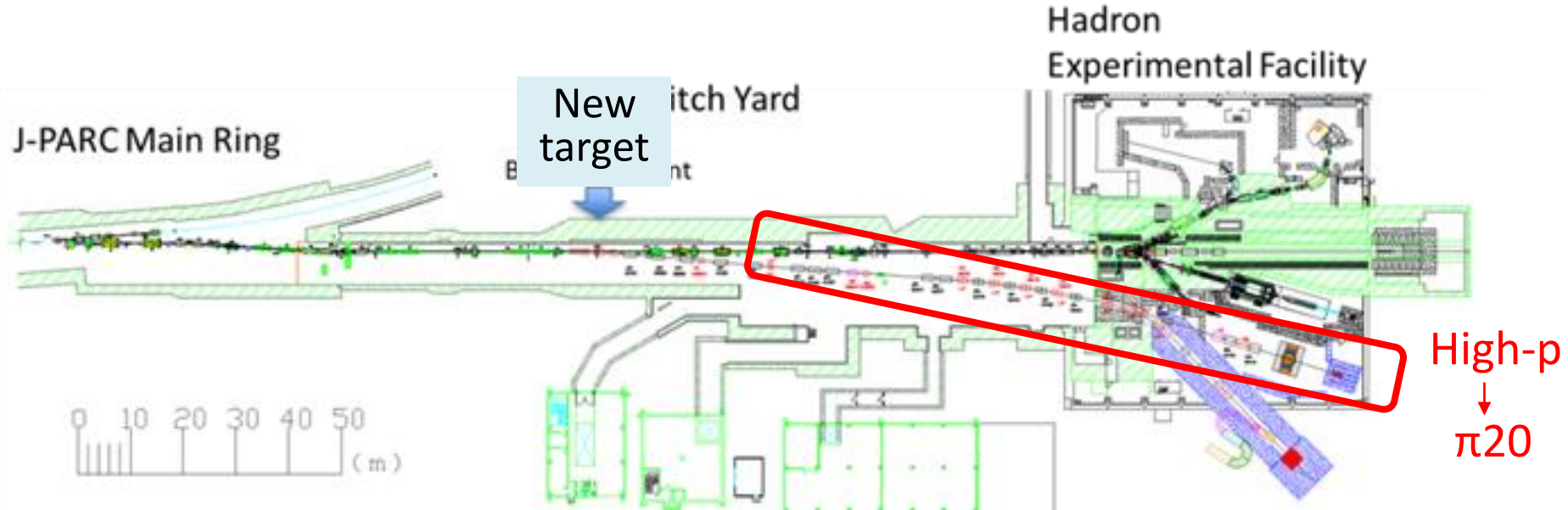

- 2020 : New high-p beamline = 30 GeV primary proton beam

Upgrade

- New target
- Polarity change
- Focusing magnets

- 202X : **$\pi 20$ beam line** = Positive and negative secondary beam ($\pi/K/p$) in wide momentum range (2-20 GeV/c)

Physics program @ $\pi 20$ beamline

- **Hadron structure**

- Charmed baryon spectroscopy
- Ξ ($s=-2$) baryon spectroscopy

- **Exotic hadrons**

- High isospin dibaryon search
- Pentaquark search

- **Nucleon structure**

- Measurement of Generalized Parton Distribution Functions (GPDs)
- Color Transparency

- **Elementary cross sections**

- Λp scattering cross section
- Hadronic cross sections for neutrino experiments

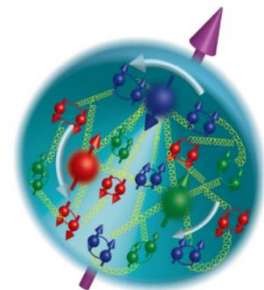
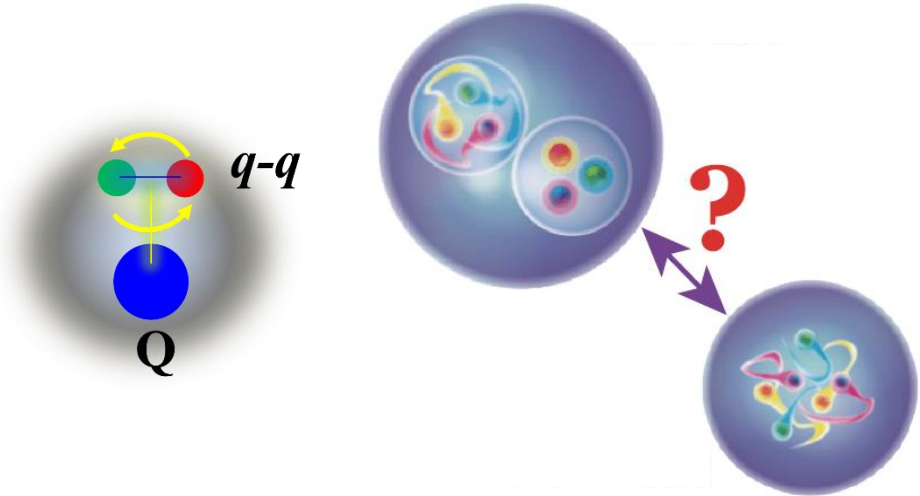

GPDs measurement at J-PARC

Generalized Parton Distributions (GPDs)

- 3-dimensional distribution of partons in a nucleon

Forward limit : 1D Parton Distribution Functions

1st moments : Form Factor

2nd moments : Gravitational Form Factor

→ Total spin, mass of partons

Probe the origin of nucleon spin and mass

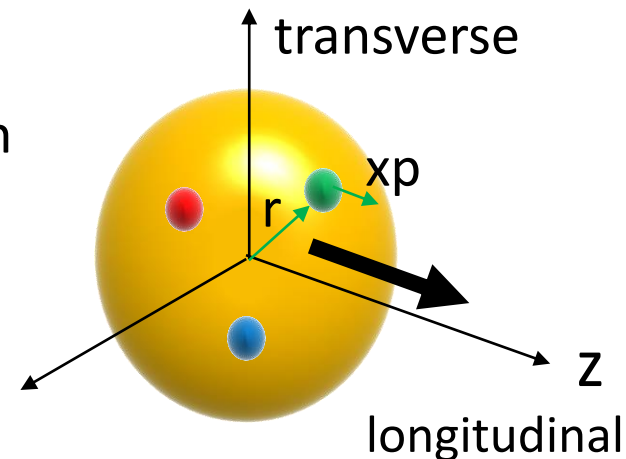

First measurement of GPDs using hadron beam

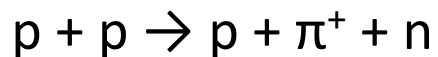

PRD 80 (2009) 074003



PRD 109 (2024) 074023



PRD 93 (2016) 114034

Complementarily to the ordinally lepton induced reactions

- $l + p \rightarrow l' + p' + \gamma$: Deeply Virtual Compton Scattering (DVCS)
- $l + p \rightarrow l' + p' + M$: Deeply Virtual Meson Production (DVMP)

MARQ Spectrometer

Multi-Purpose Analyzer for Resonance and Quark dynamics

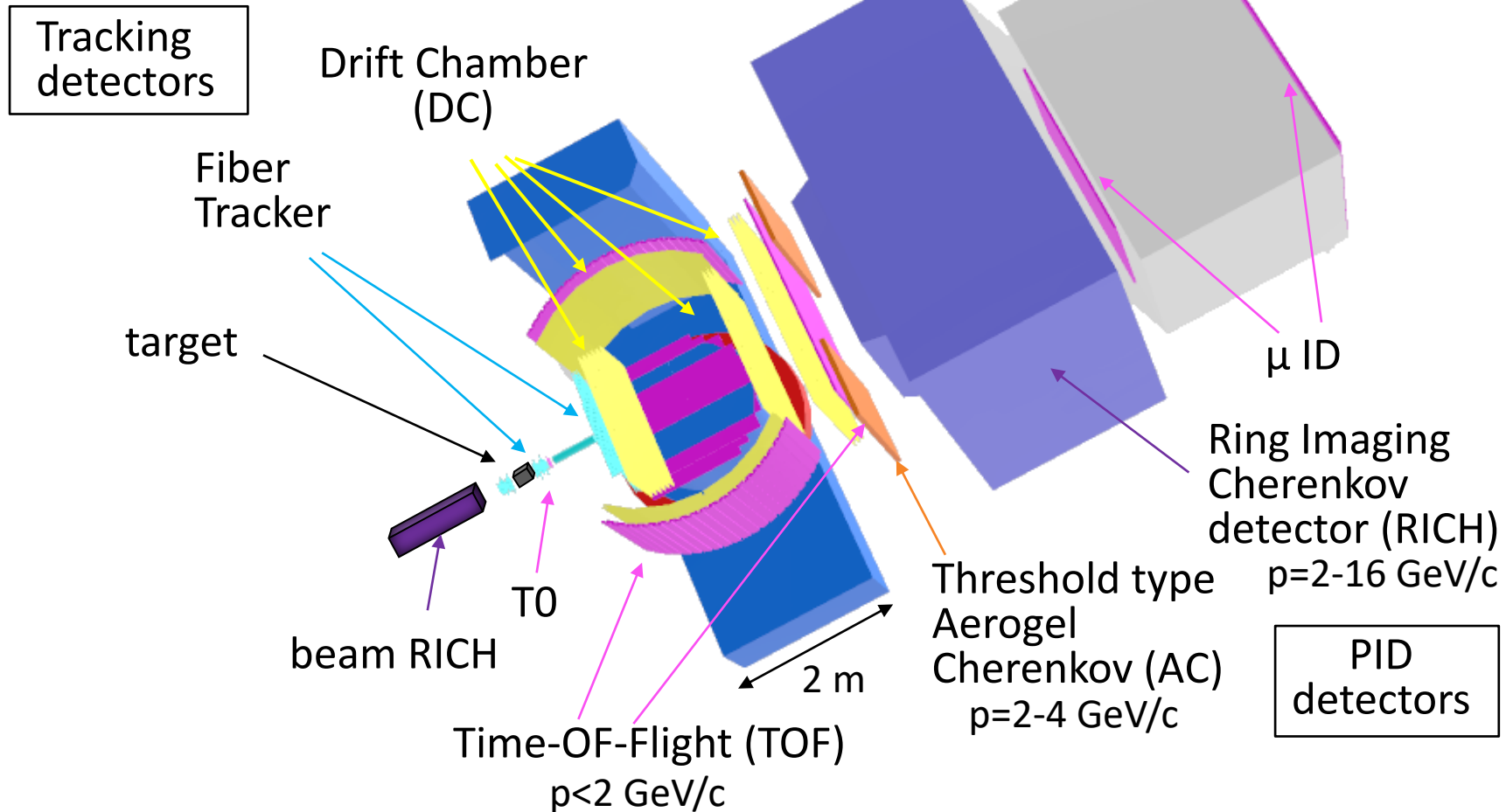

- Streaming DAQ : no hardware trigger, online filtering
- High rate stability : 1MHz/1 mm @ center
- Large acceptance • High momentum resolution

R. Honda et al.,
PTEP 123H01 (2021)

MARQ MRPC

Multigap Resistive Plate Chamber (MRPCs)

2023 : [FJPPN_D_RD_30] followed with [2017-2022 FKPPL CMS-RPC]

2024 : Prof. Imad Laktineh from [FKPPL HPRPC] joins our FJPPN member

Side TOF

1.6 m long

Goal : $\sigma_{\text{time}} = 60$ ps
in magnetic field

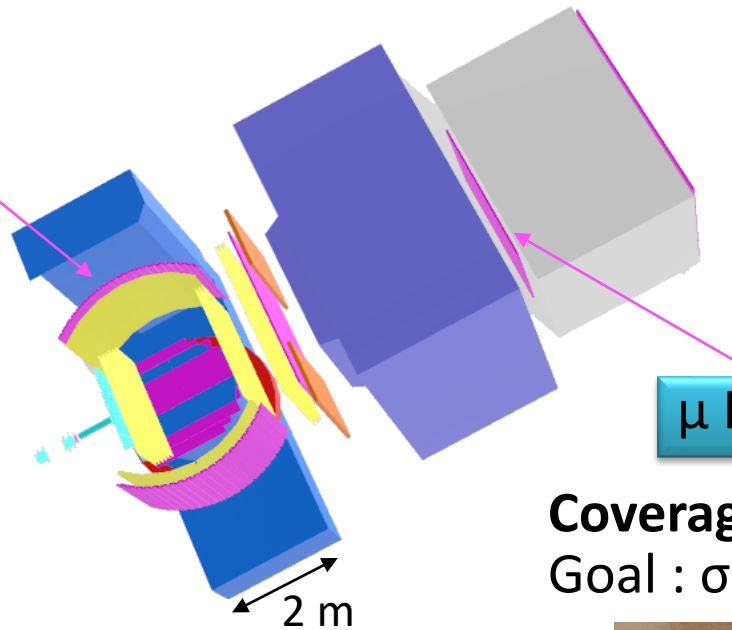
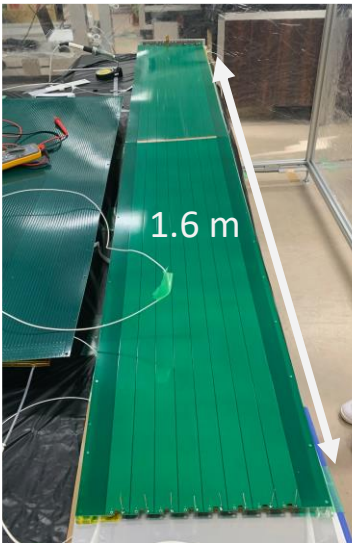

μ ID tracker

TOF-tracker

Coverage area : 2.4 m \times 1.8 m

Goal : $\sigma_{\text{pos}} = 1$ mm, $\sigma_{\text{time}} = 100$ ps

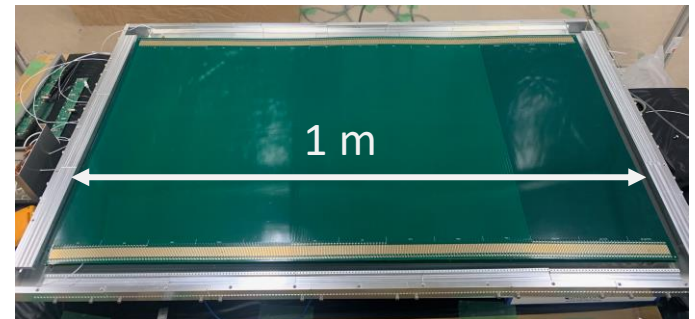

MRPC for muon tomography

[FKPPN HPRPC]

Development of (M)RPC for muon tomography

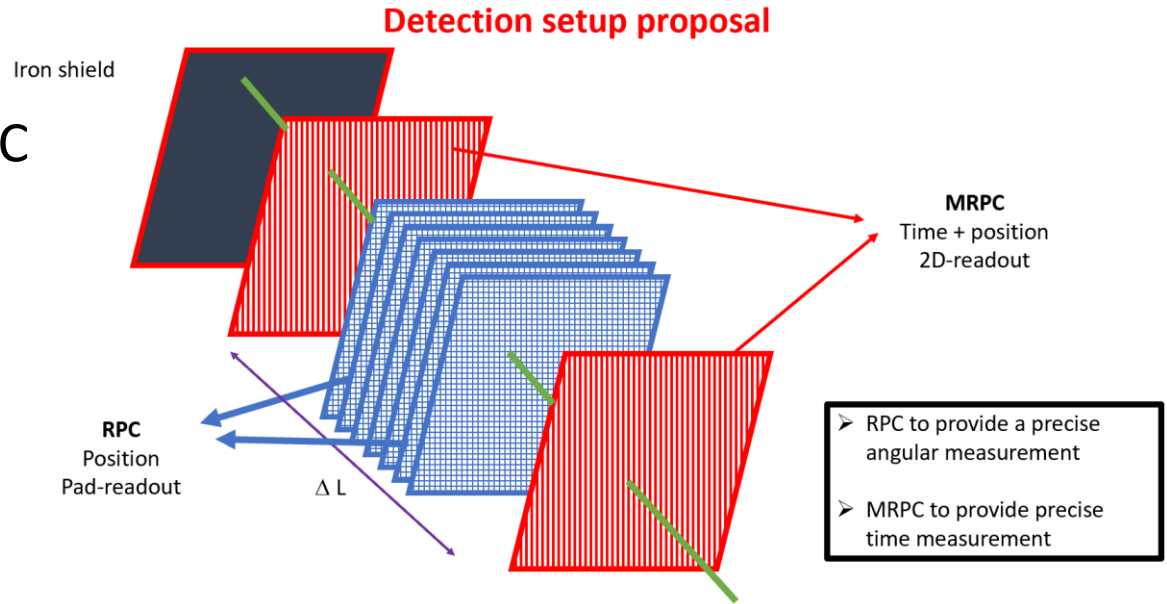

[FJPPN_D_RD_30]

2024-2028 : JST K program
“Development of TOF-tracker
MRPCs for volcano muon
tomography”



TOF-tracker MRPC development for common goal !!
Within Work Package7 of Detector R&D (DRD1)

Multigap Resistive Plate Chamber

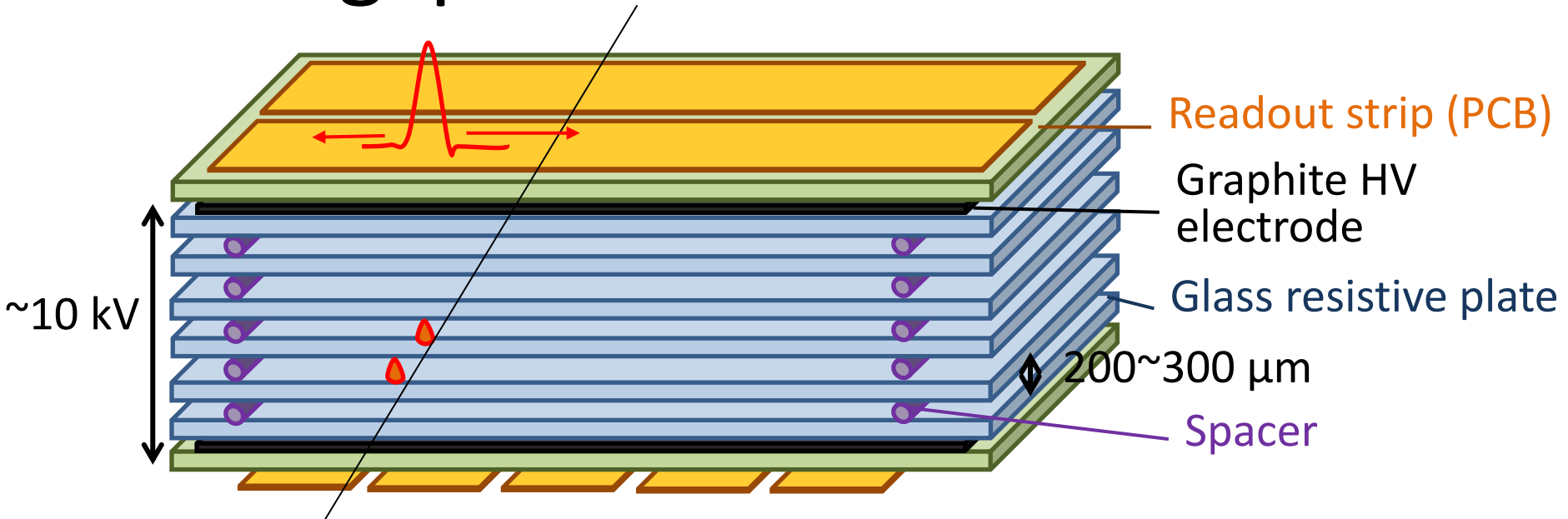

FJPPN project

Readout strip

Graphite HV electrode

Gas tight

Gas gap spacer

TOF : Production of PCBs in French factory

Tracker : Test novel wire readout in Japan

Japanese carbon tape discontinued

⇒ Test alternative France & Japan products

Methods developed in France

Fishing line → round spacer in France & Japan

FY2023 Visit : Lyon University

Gas tight

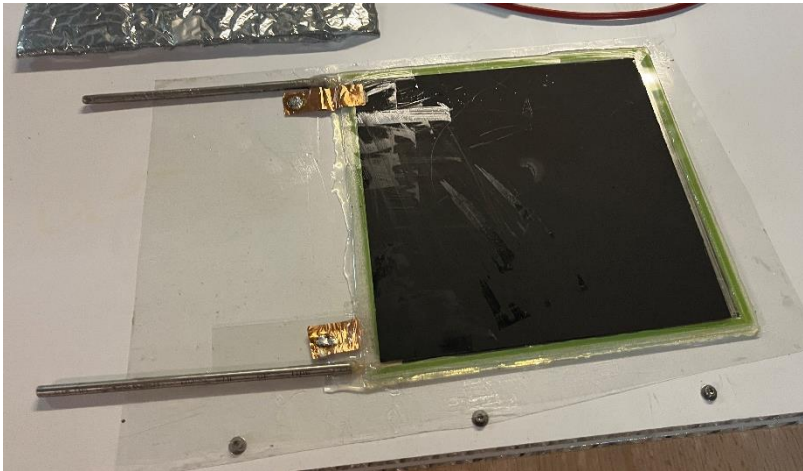

Carbon ink for HV electrode

Gas Spacer

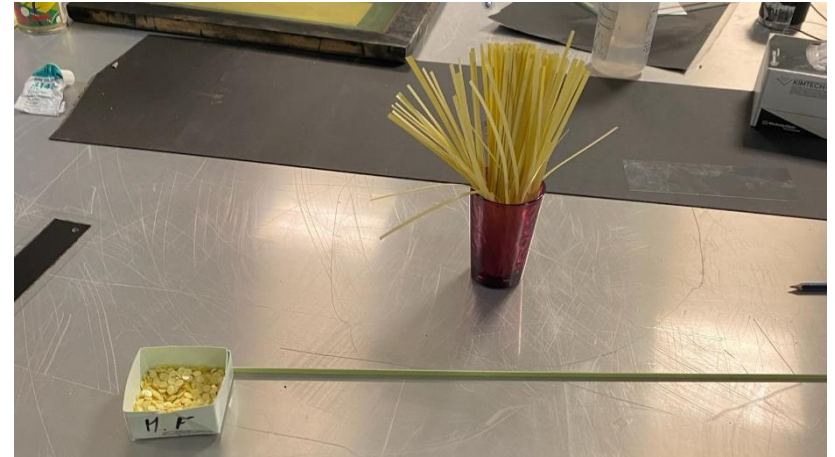

PCB soldering / qualification tests

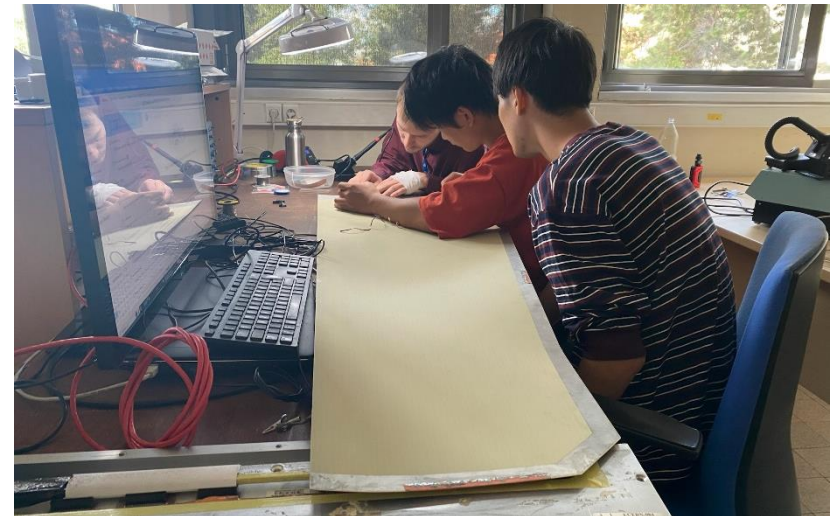

Learned techniques of Lyon/IP2I !

FY2023 Visit : CERN & ELVIA(factory)

Joined assembling of CMS-iRPC

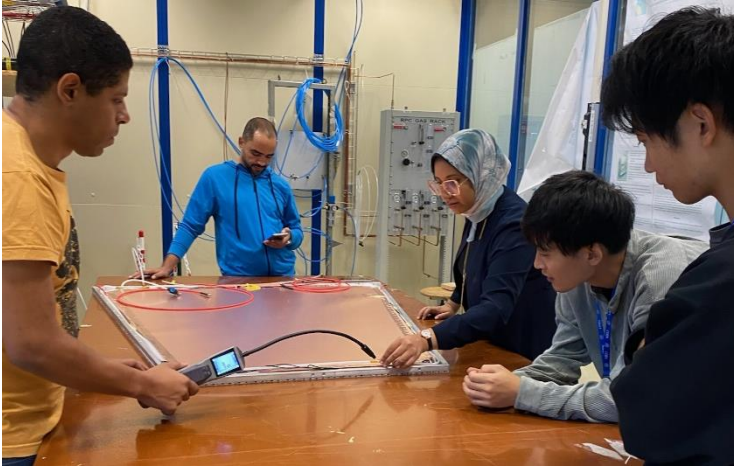

PCB production company



Fruitful stay

We appreciate for the FJPPN support !!

FY2023 after visit

- Prototype MRPC with Lyon's gas tight / gas spacer

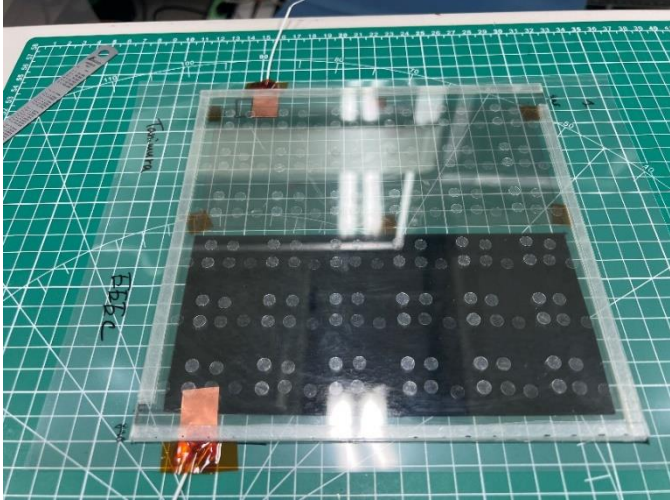

Basic performance : OK
Some sparks

- Prototype MRPC with Lyon's carbon ink / new gas spacer

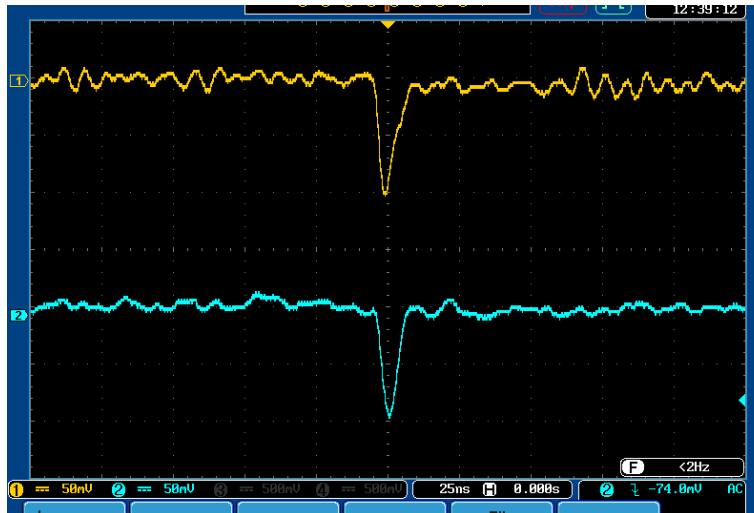
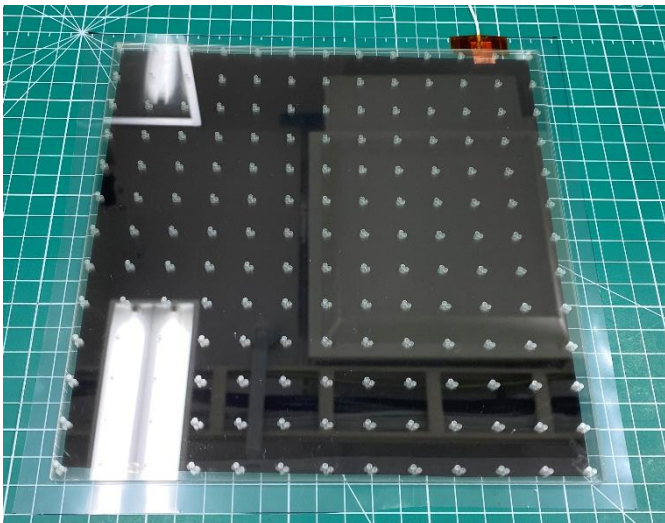

Beam test in
2024/Jul

TOF-tracker beam test

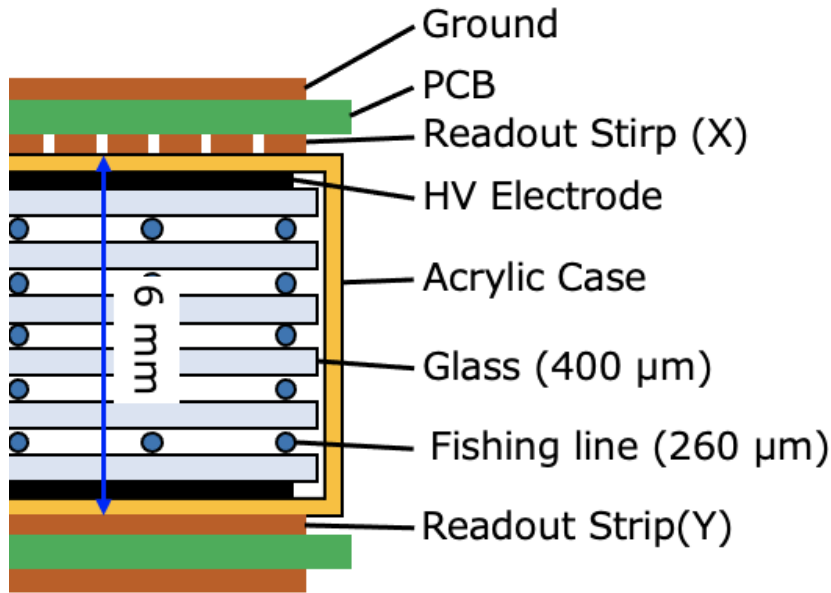

- 1000 mm x 500 mm
- 5 mm pitch readout strip
- Discontinued carbon / old gas tight

Achieved required performance !!

Best condition

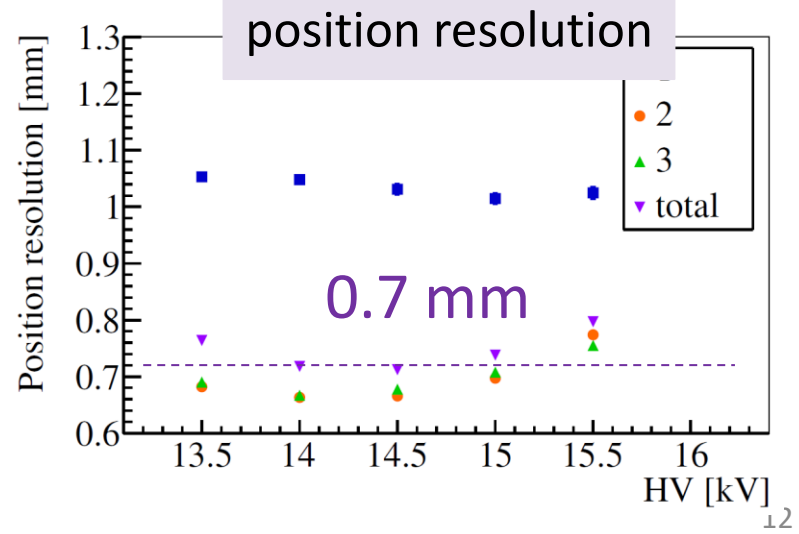
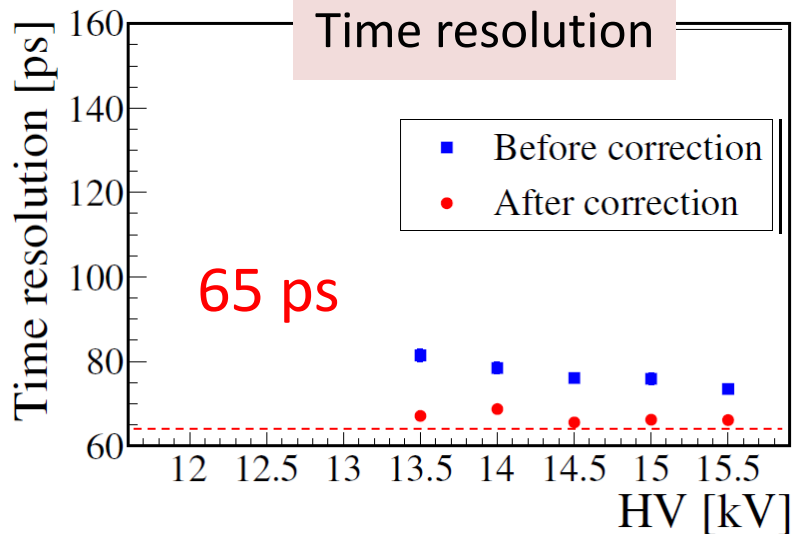

TOF prototype beam test

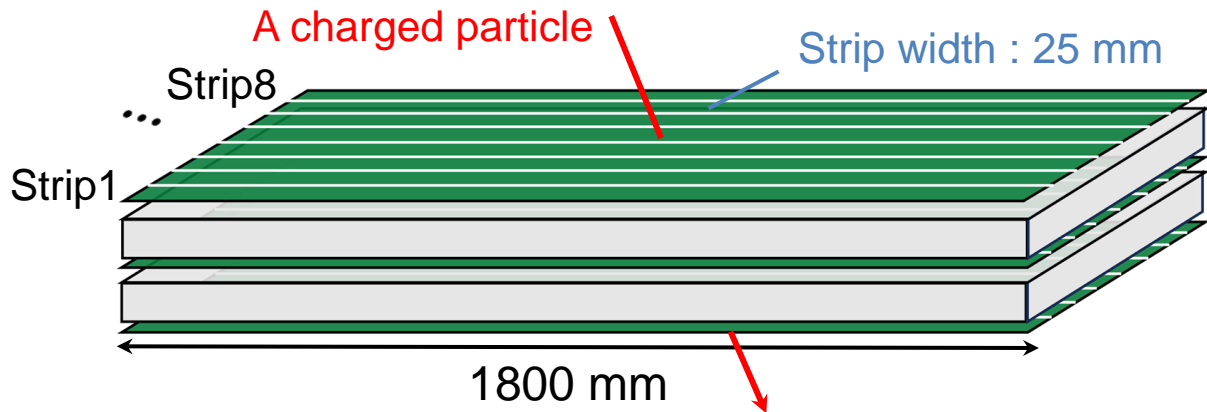

- (25 mm x 900 mm) x 2 readout strip
- Connect two PCBs using Cu tape
- Discontinued carbon / old gas tight

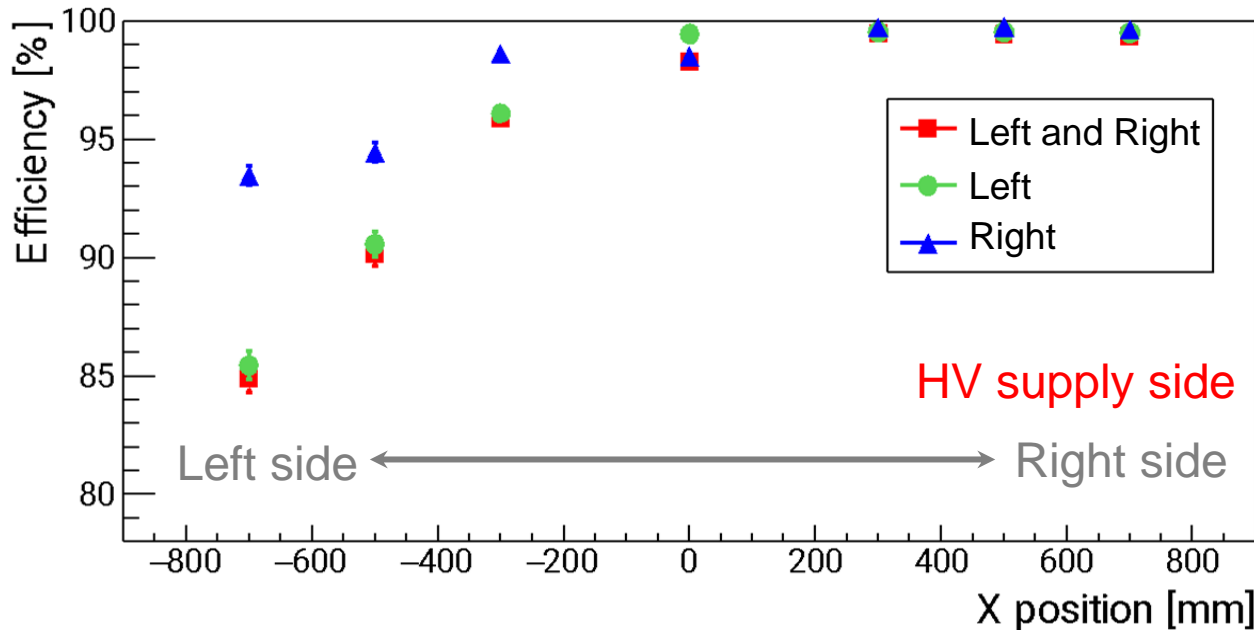

- Low efficiency at the far side from HV supply
⇒ Because of unexpected high resistivity of carbon tape

Test alternative carbon ⇒ Production of 1600 mm strip PCB in France

FY2024 plan

- Develop new spacer/gas tight system in France & Japan
- Design readout PCB for production in France
- Test prototype MRPC with Lyon's carbon ink & Japanese polymer ink
Beam test in 2024/Jul
- Test wire readout tracker MRPC
Beam test around 2024/Nov

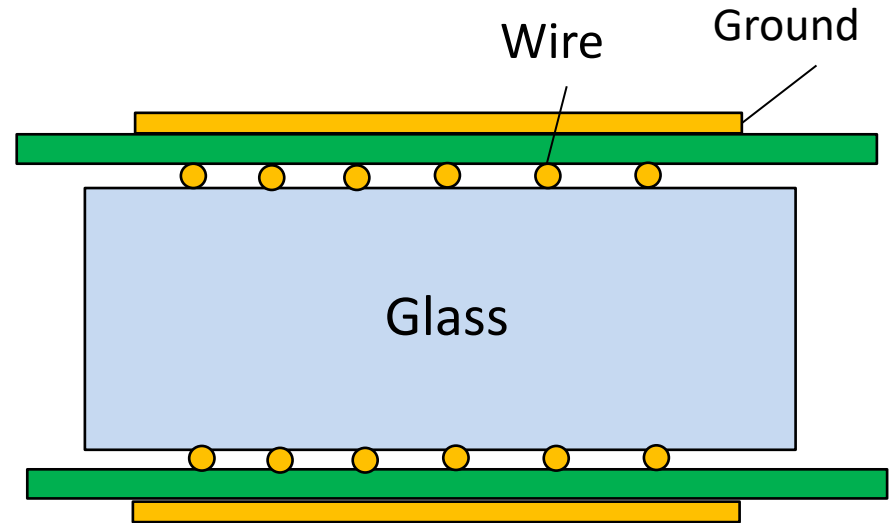
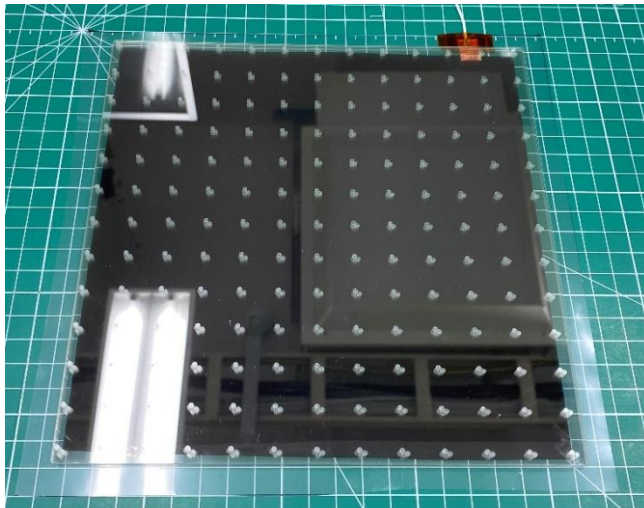

French people will join the beam test

- Japanese member will join CMS-iRPC installation work

Summary

- High momentum secondary beamline ($\pi 20$ beamline) will be constructed at J-PARC
- A multi-purpose MARQ spectrometer is under construction
- **MARQ MRPC** development within a **FJPPN project** from last year
 - TOF-MRPC : 1.6 m-long, $\sigma_{\text{time}} < 60$ ps
 - Tracker-MRPC : $\sigma_{\text{pos}} < 1$ mm and $\sigma_{\text{time}} < 100$ ps
- New usage of TOF-tracker MRPC for muon tomography \Leftrightarrow **FKPPN HPRPC**
- Fruitful visit to France in FY2023
- Build MRPC with Lyon/IP2I method
 - Graphite HV electrode
 - Gas tight
 - Gas gap spacer
- Beam test of prototype MRPCs using old method
- Beam tests of prototype detectors based on Lyon's technique in FY2024
- Visit France/Japan to learn technique of each country

Members

France

Gouzevitch Maxime (Senior Scientist, IP2I)
Garde Gustave (Engineer Assistant, IP2I)
Imad Laktineh (Professor, Lyon University)

Japan

Natsuki Tomida (Assistant Professor, Kyoto University)
Ryotaro Koike (Master student, Kyoto University)
New student