

# Constraints on Generalized Neutrino Interactions in the keV Region of the Tritium $\beta$ -Decay Spectrum

Jeong Yeol Yang

*Yong Chang Lee*, Kyung Rae Woo, Yong Hamb Kim

# Motivation

- Neutrino has mass but not for SM.
- What is made of the dark matter?
- Way to solve above problem SIMPLY?
- What if heavy neutrino which feebly mixed with neutrino
- X-ray in decay of heavy neutrino
  - depending on cosmological heavy neutrino production
  - DW, Shi-Fuller mech., Reheating temperature(MeV? GeV?)
- **Need model independent measurement**

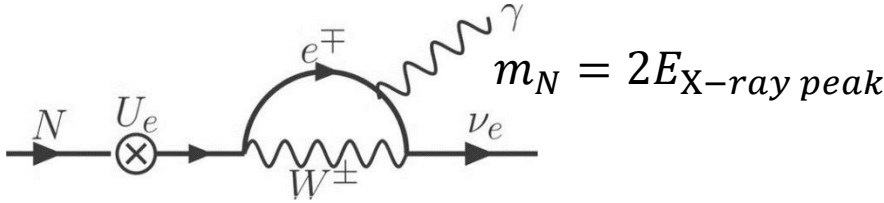
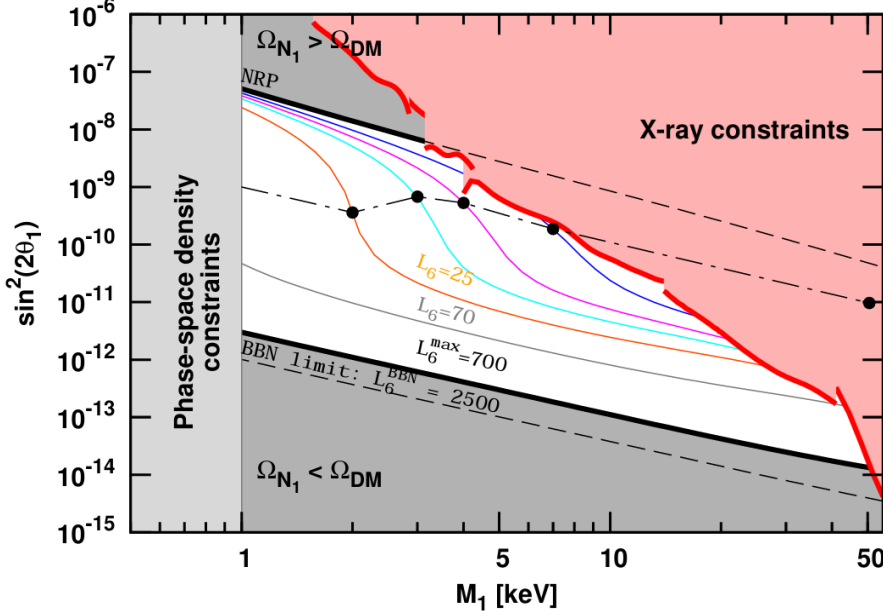

$$\Gamma_{N \rightarrow \nu \gamma} = \frac{9 \alpha G_F^2}{1024 \pi^4} \sin^2(2\theta) M^5 \simeq 1.38 \times 10^{-22} \sin^2(2\theta) \left( \frac{M}{1 \text{ keV}} \right)^5 \text{ s}^{-1}$$

# Why **tritium** beta spectrum?

- Very well studied comparably easy in approximation.
  - : Only 3 nucleons(pnn), 1 or 2 electrons.
  - : Well defined effective Lagrangian, atomic and relativistic correction
- WDM for keV-scale mass,  $Q=18.59\text{keV}$ .
- Enough reliable precedent experiments (e.g. KATRIN, Mainz, Troitsk)

*PhysRevC.77.055502*

The invariant  $\beta$ -decay amplitude is given by

$$M = \frac{G_{FVud}}{\sqrt{2}} \bar{u}(P_e) \gamma_\alpha (1 - \gamma_5) u(P_\nu) \times \bar{u}(P_f) \left[ G_V(q^2) \gamma^\alpha + i \frac{G_M(q^2)}{2M_i} \sigma^{\alpha\beta} q_\beta - G_A(q^2) \gamma^\alpha \gamma_5 - G_P(q^2) q^\alpha \gamma_5 \right] u(P_i).$$
$$G_V(q^2) = \frac{g_V}{\left(1 - \frac{q^2}{M_V^2}\right)^2}, \quad G_M(q^2) = \frac{g_M}{\left(1 - \frac{q^2}{M_V^2}\right)^2},$$
$$G_A(q^2) = \frac{g_A}{\left(1 - \frac{q^2}{M_A^2}\right)^2}.$$

# ROI for measurement

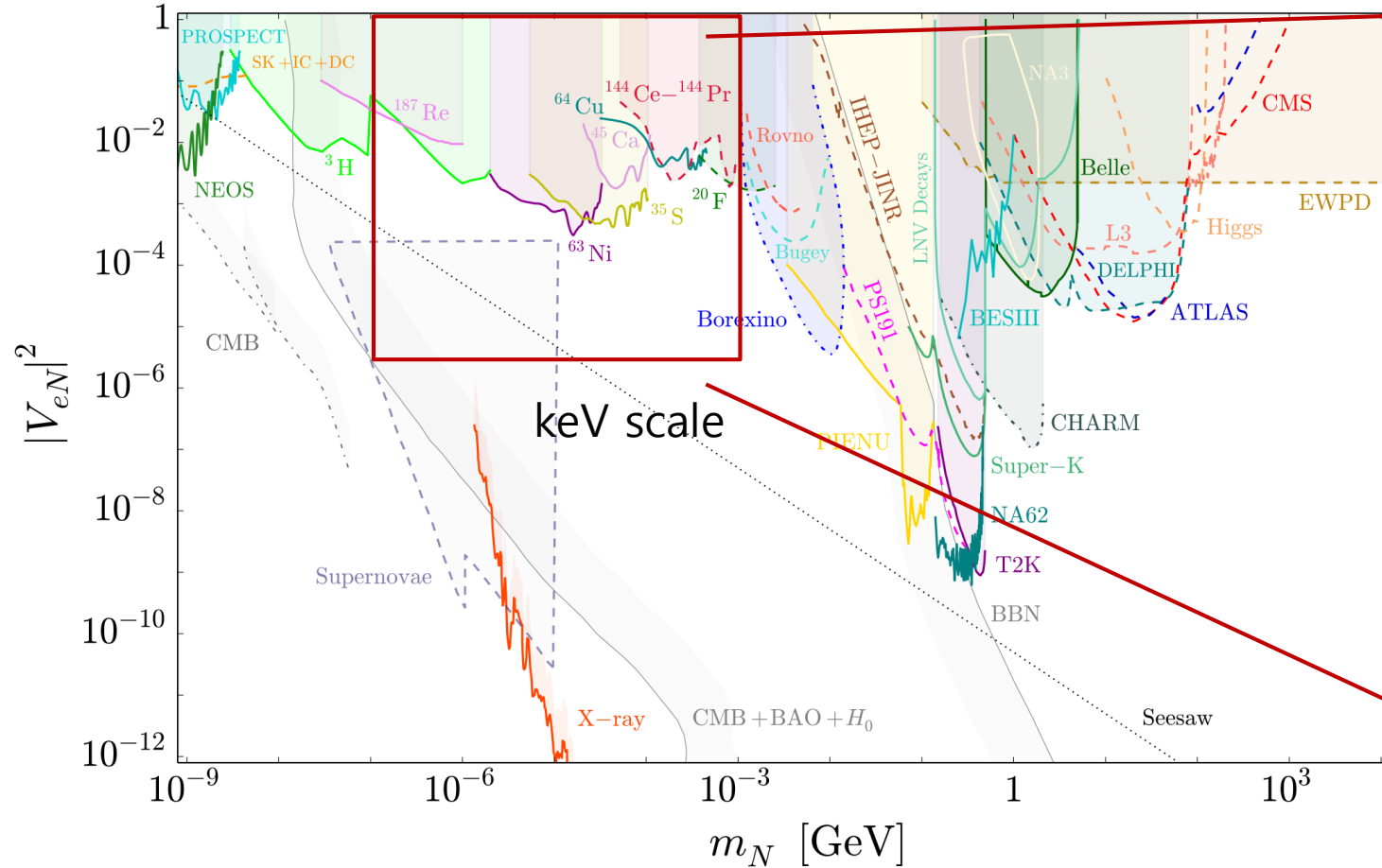

## ROI of this work

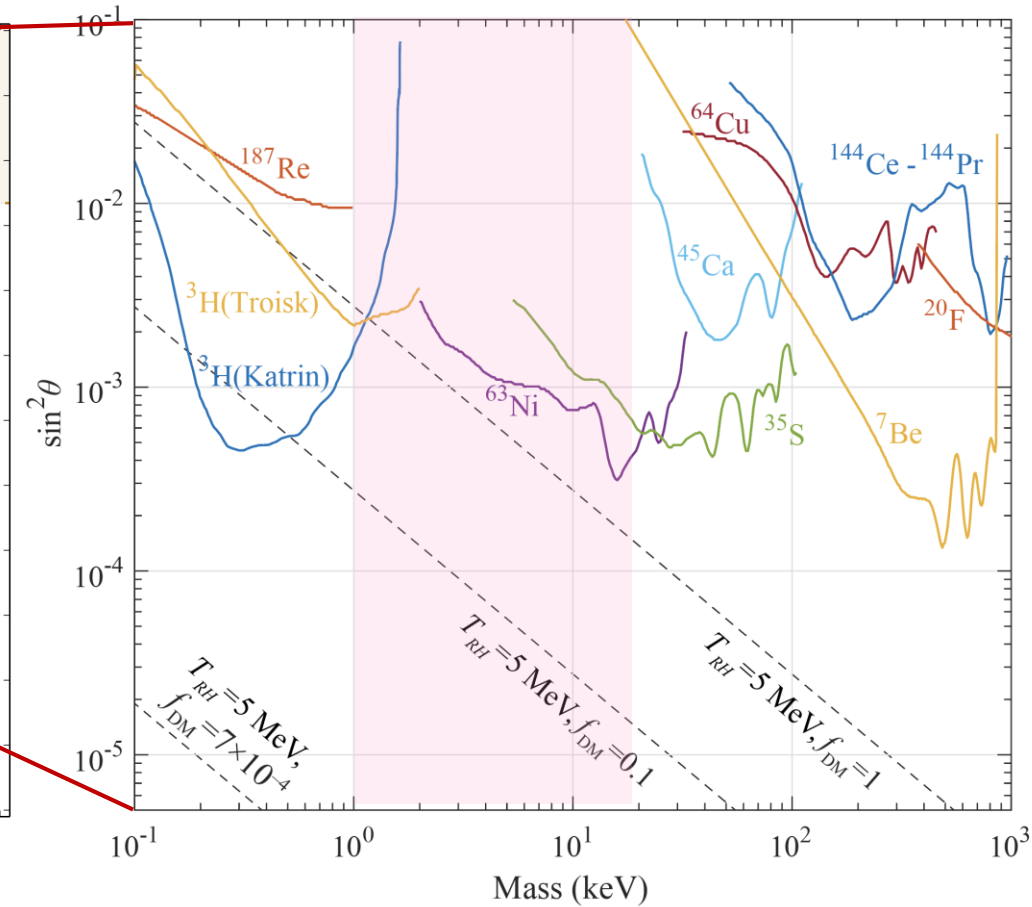

JHEP. 2020, 170

The dashed lines from Low Reheating Temperature (LRT) model Abazajian, PRD (2023)

# $^3\text{H}$ $\beta$ -decay Spectrum with sterile $\nu$ emission

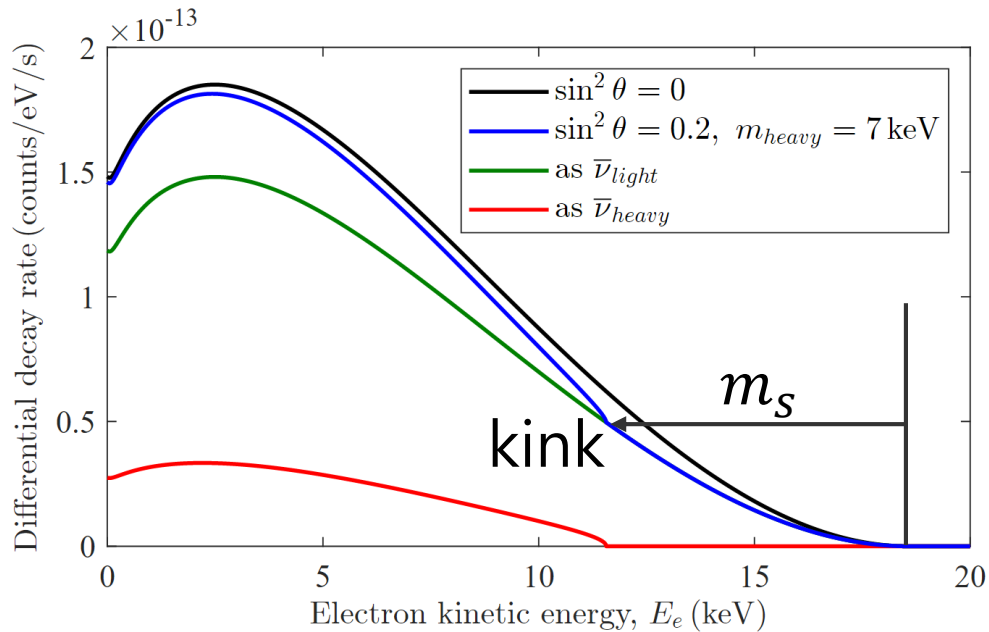
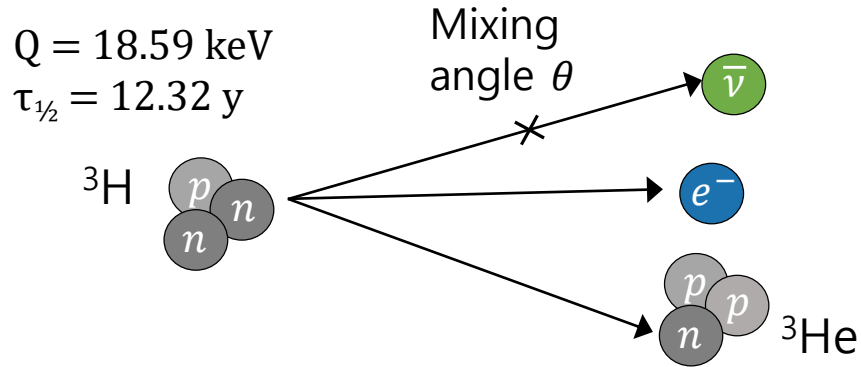

- Sterile neutrino ( $\nu_s$ ) feebly mixing with active neutrino ( $\nu_e$ )

$$\begin{pmatrix} \nu_e \\ \nu_s \end{pmatrix} = \begin{pmatrix} \cos \theta & \sin \theta \\ -\sin \theta & \cos \theta \end{pmatrix} \begin{pmatrix} \nu_{\text{light}} \\ \nu_{\text{heavy}} \end{pmatrix}$$

$$\frac{d\Gamma_{\text{tot}}}{dE}(E_e; m_{\text{light}}, m_{\text{heavy}})$$

$$= \cos^2 \theta \frac{d\Gamma}{dE}(E_e; m_{\text{light}}) + \sin^2 \theta \frac{d\Gamma}{dE}(E_e; m_{\text{heavy}})$$

- $\beta$ -decay spectrum for  $\nu_{\text{heavy}}$  is added to that for  $\nu_{\text{light}}$  with angle normalization factor.
- Non-differentiable point at  $Q - m_s$

# Measurement of decay event

- Beta with kinetic energy  $\rightarrow$  deposited in crystal as heat  $\rightarrow$  Heated Ag:Er under current coil  $\rightarrow$  Induced current in coil  $\rightarrow$  Signal in SQUID

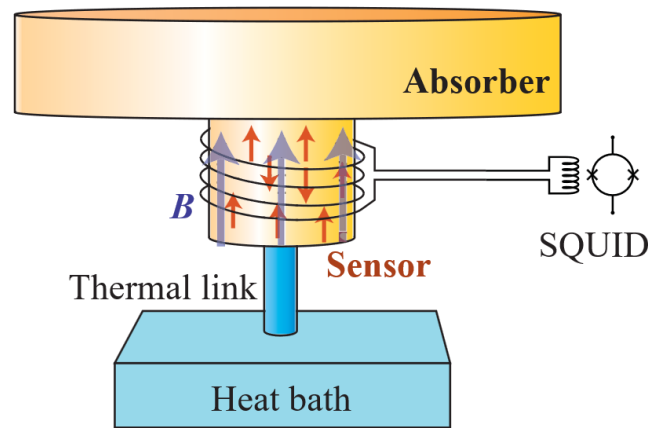

- Paramagnetic alloy in a magnetic field
- Au:Er, Ag:Er (300-1000 ppm)
- Metal host - Fast thermalization
- High resolution
- Good linearity
- Large dynamic range  $\delta T \approx \frac{\delta E}{C_{tot}}$

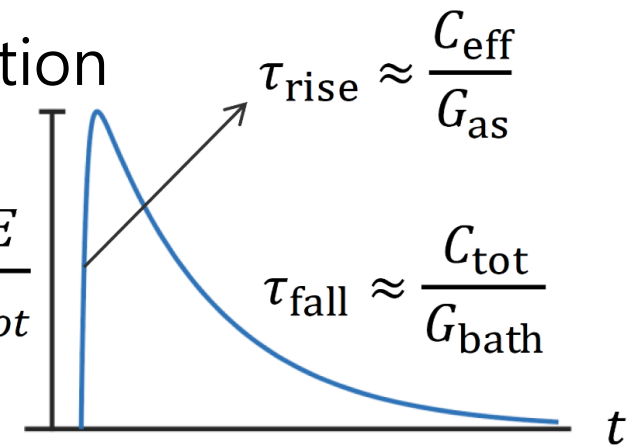

# Measurement of decay event

- Beta with kinetic energy  $\rightarrow$  Heat in crystal  $\rightarrow$  Heated Ag:Er under current coil  $\rightarrow$  Induced current in coil  $\rightarrow$  Signal

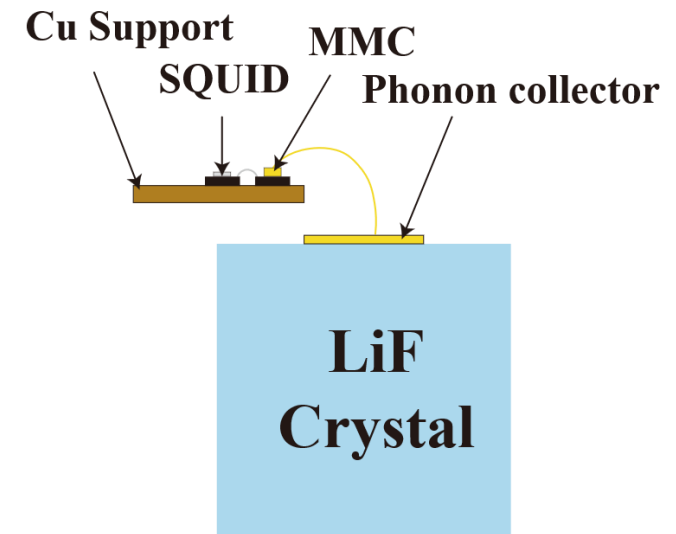
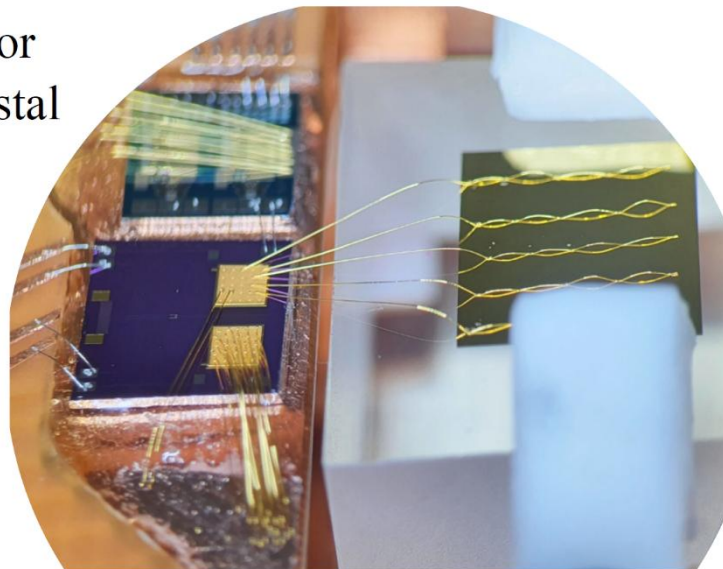
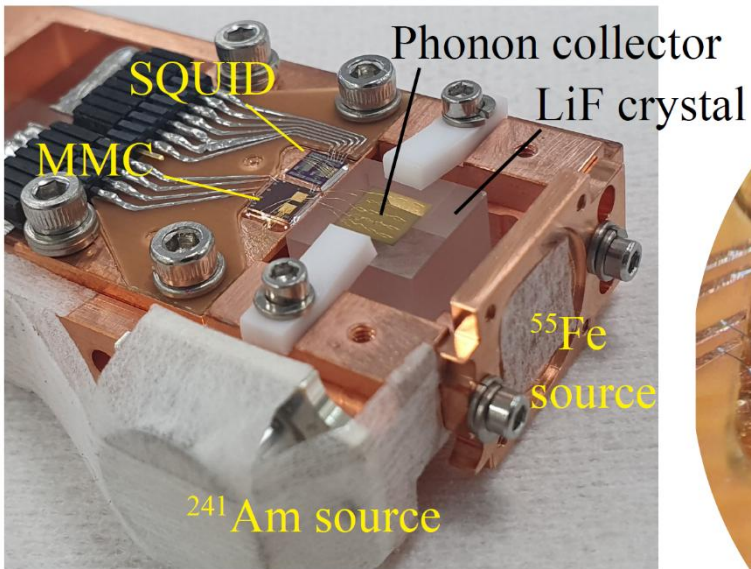

# Detector Performance Basics (**Before** neutron activation)

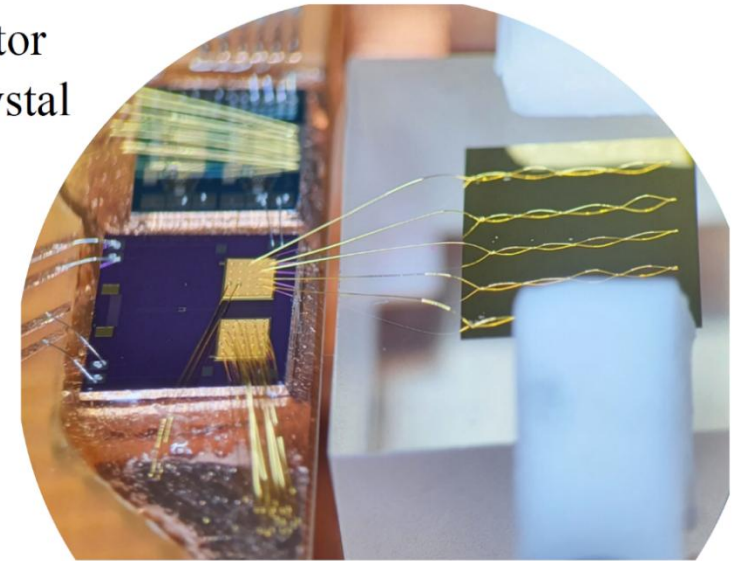
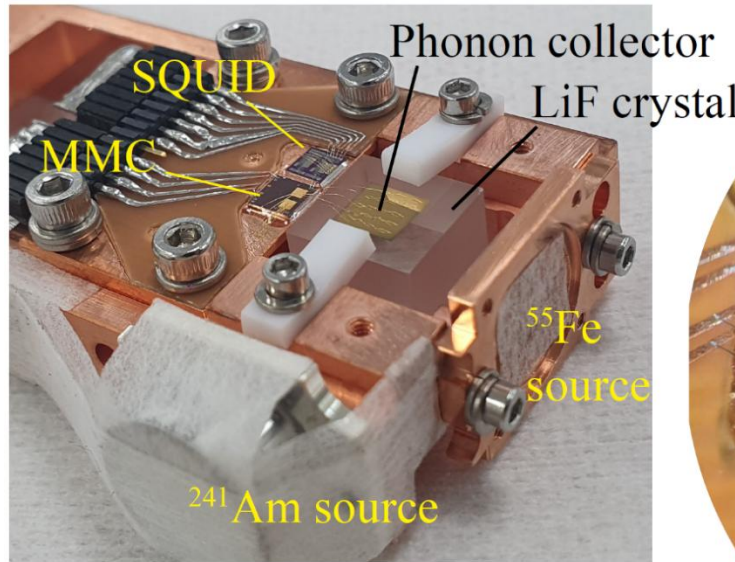
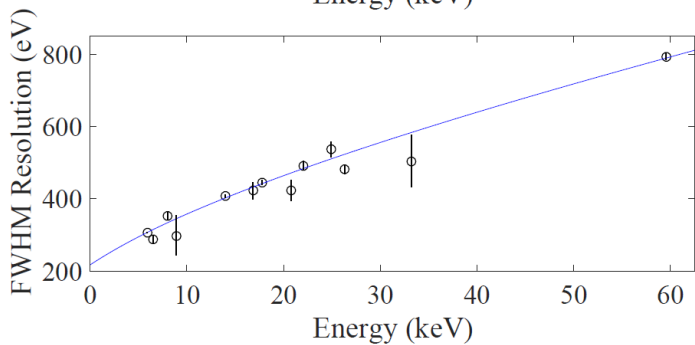
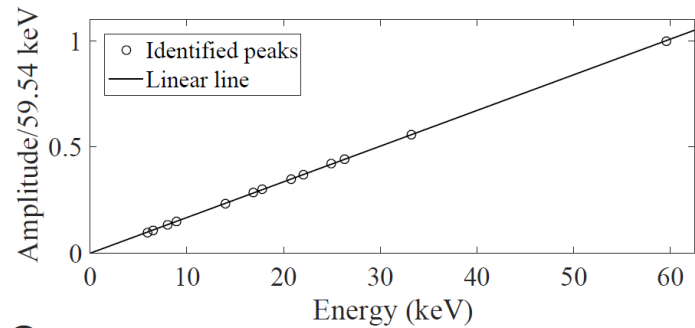
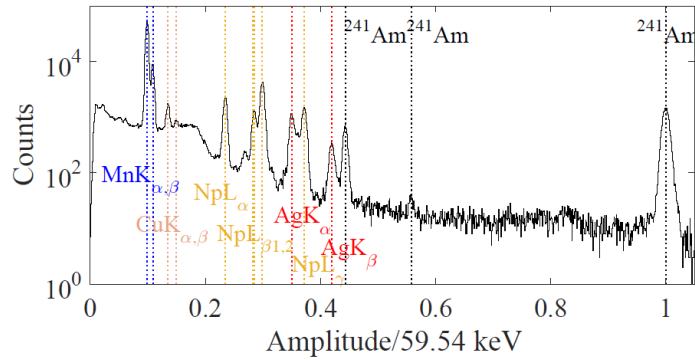

Measurement with internal  $^{55}\text{Fe}$  and  $^{241}\text{Am}$  sources

- Background measurement
- All the peaks are clearly identified.
- Excellent linearity in energy calibration
- Excellent energy resolution (0.2~0.4 keV FWHM) in the ROI

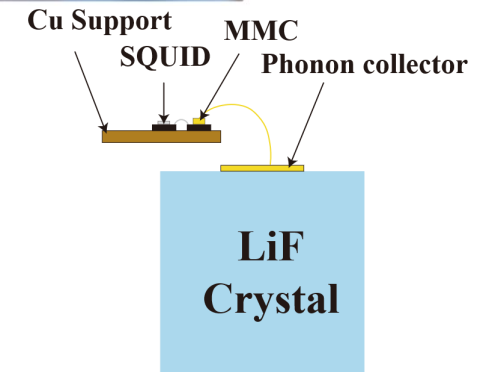

# $^3\text{H}$ Production in LiF Cubic Crystals

Mean free path:  
2.3 mm in LiF with 7.6 %  $^6\text{Li}$

LiF location:  
Center of the storage

Neutron irradiation at KRISS  
Week exposure  $\rightarrow$  20 Bq  $^3\text{H}$

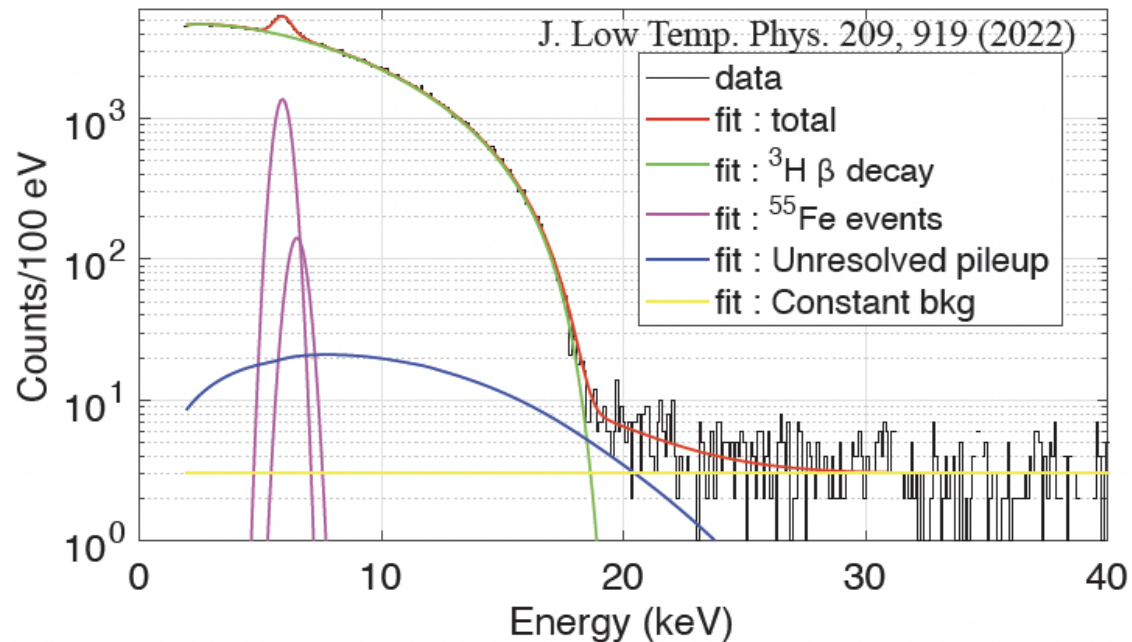
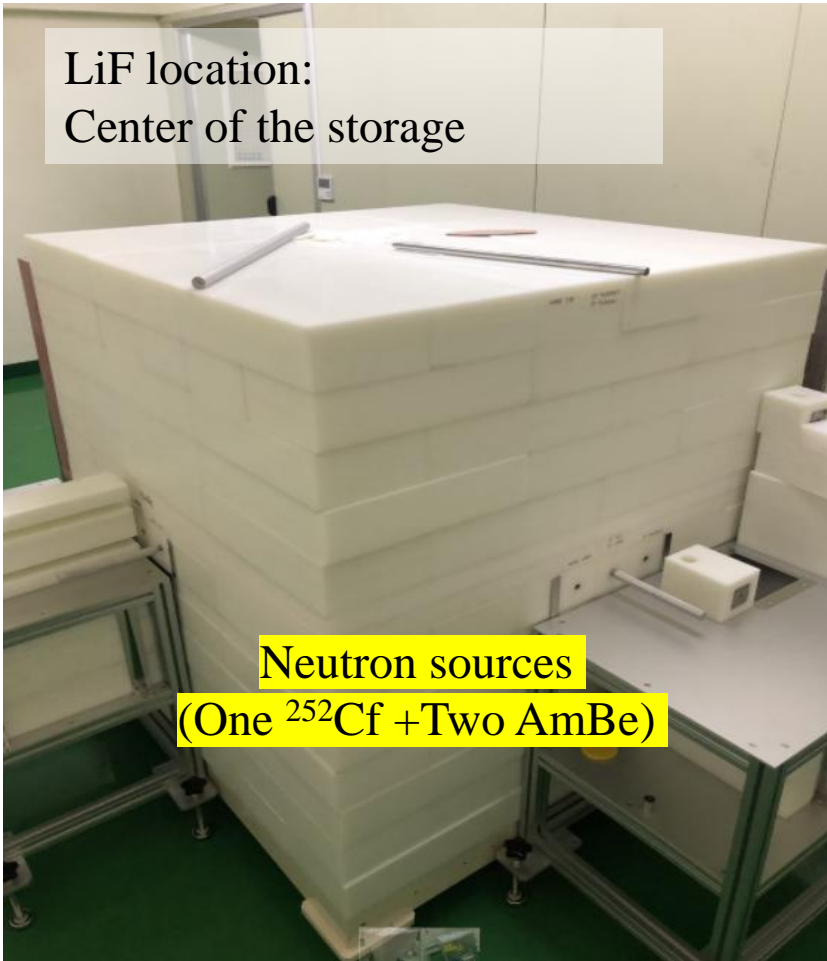
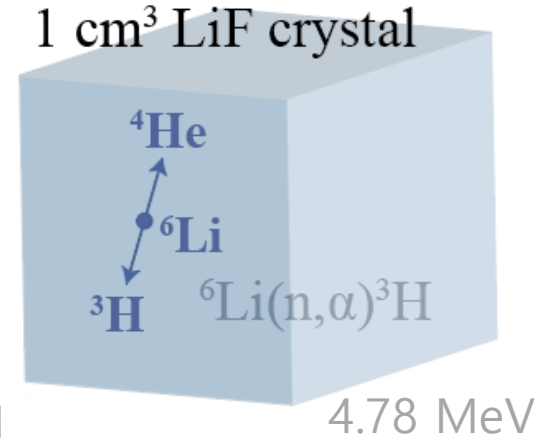
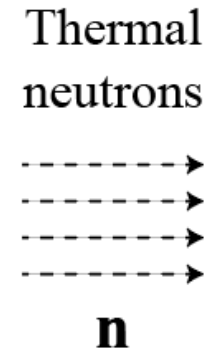

10-hour spectrum  
using the first LiF( $^3\text{H}$ )  
with  $^{55}\text{Fe}$  source

# Surface issues ( $^3\text{H}$ distribution and energy loss)

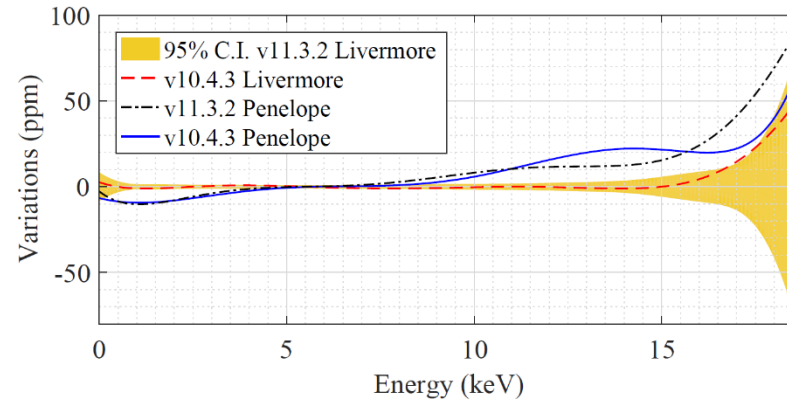
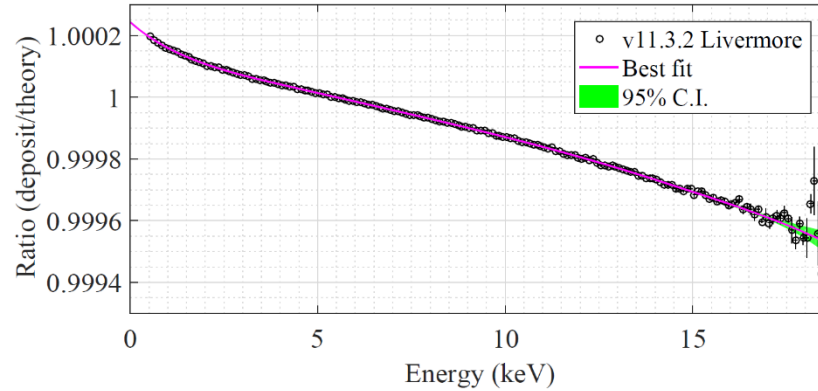
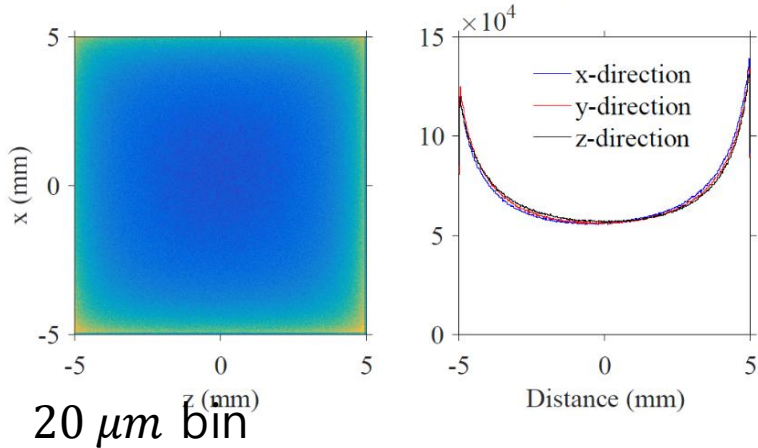
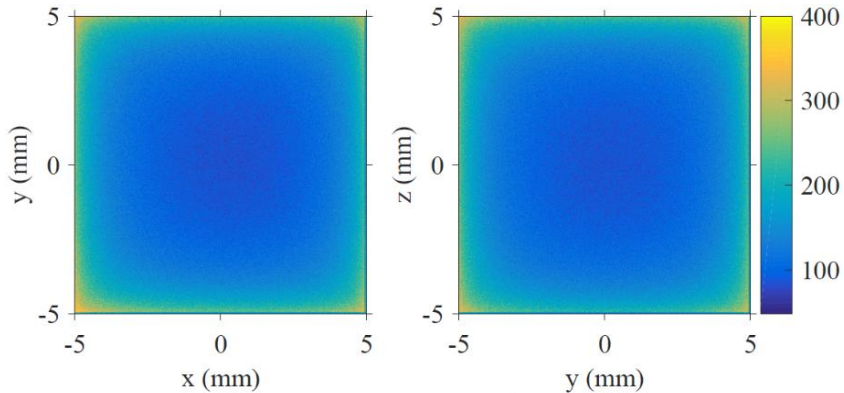

- ✓ **Non-uniform  $^3\text{H}$  distribution LiF**  
:  $\lambda_n = 2.3\text{mm}, r_{stop,T} = 33\mu\text{m}$
- ✓ **Possible energy loss for escape**  
:  $r_{stop,\beta(18\text{keV})}$  in LiF =  $0.5 \mu\text{m}$
- ✓ **Correction uncertainty**  
: Up to GEANT4 library, 10ppm different in energy spectrum

**These effects are well understood from MC simulation and accounted for in the analysis.**

# Background spectrum

- Fit range: 1~120keV
- Expect spectrum: full peak + continuum + bkg(3 exponential + constant)
- Full peak: Gaussian or tailed Gaussian function fitted to measured spectrum
- Continuum: from simulation, share same normalization with full peak

\*\*\* special treat: for 60keV, separate continuum into (secondary el's) and (not by secondary el's). Full peak and (not by secondary el's) share same normalization, and (secondary el's) has own normalization parameter -> X 3.2 ( fit result )

- $\chi^2 / \text{ndf} = 2640.8 / 2335$

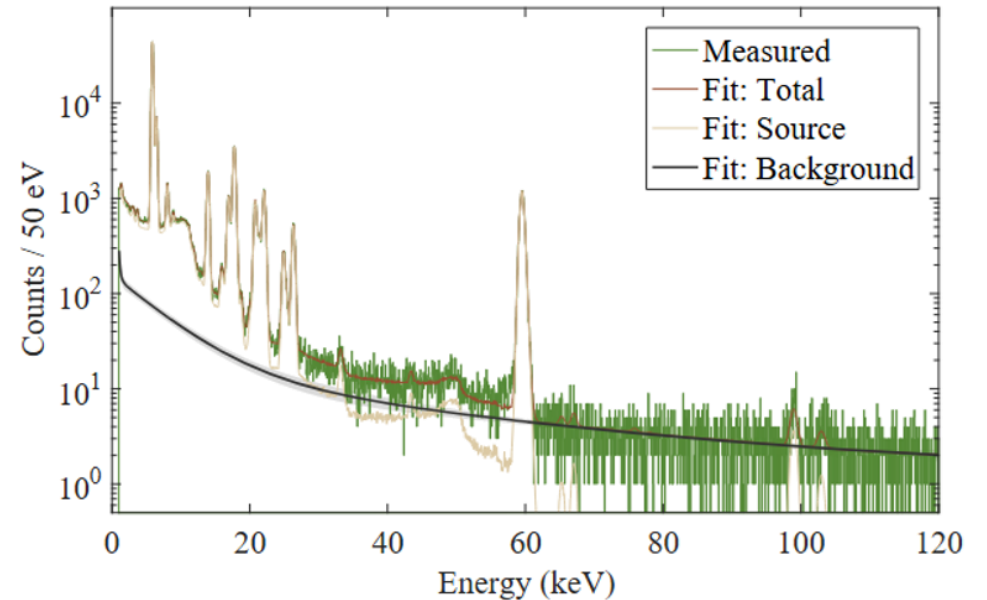
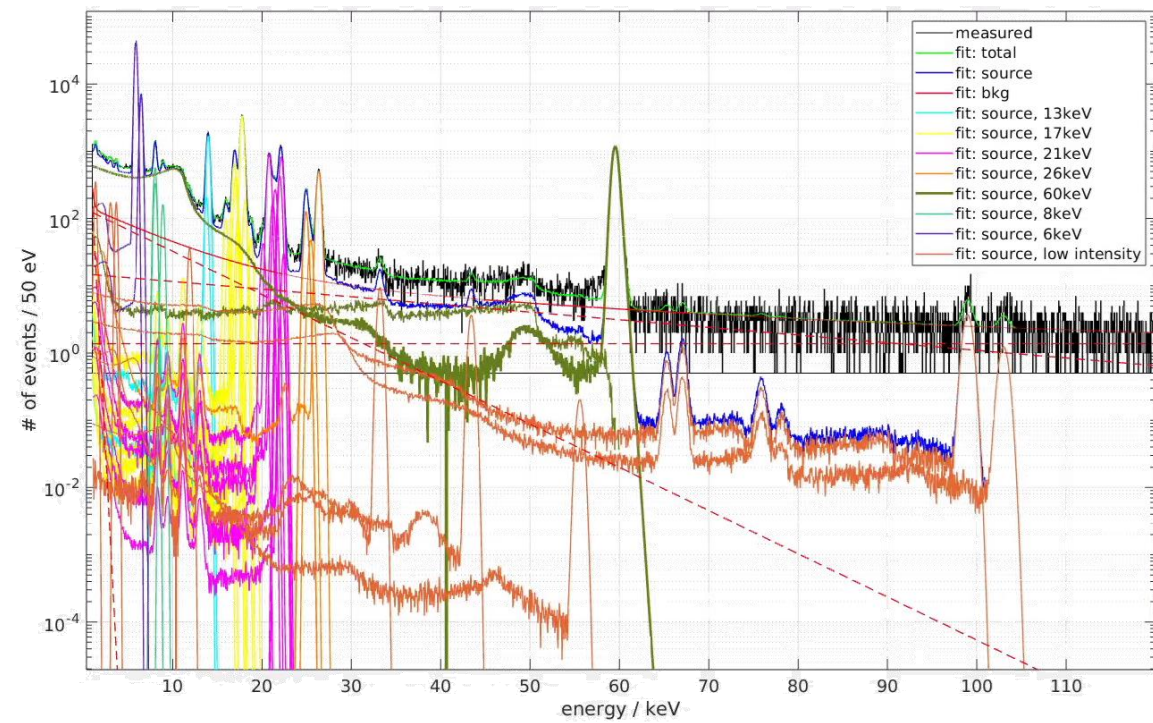

# Calibration (Energy + Position)

Simulated positions of 5.9 keV X-ray events (Mn  $K_{\alpha}$ ) absorbed in the LiF crystal from various  $^{55}\text{Fe}$  source locations used in Exp. 2–10.

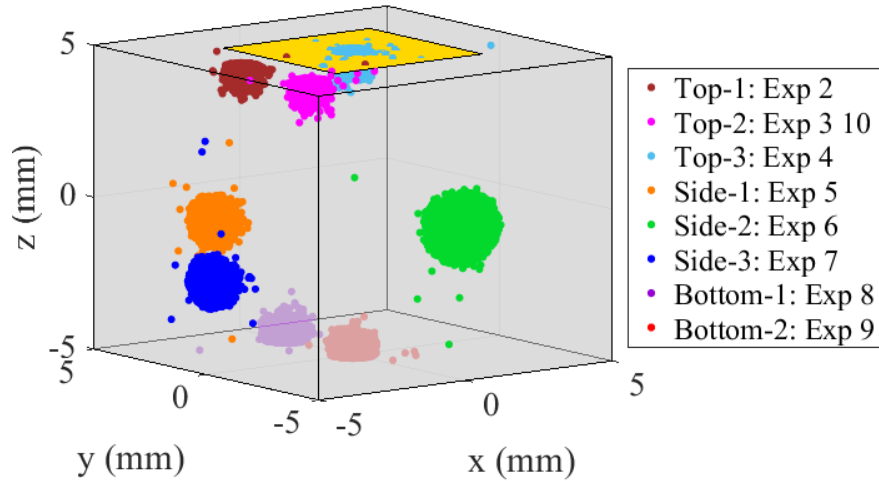

- Each peak corresponds to the energy and position of the events in the crystal.
- Various source locations ( $^{55}\text{Fe}$  and  $^{241}\text{Am}$ ) for energy-position calibrations.

$$\text{Amp} = (\text{Position function})(\alpha E^2 + \beta E)$$

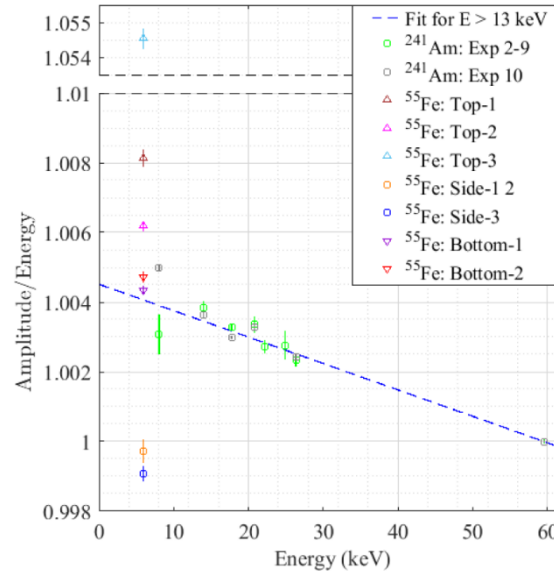

Position calibration

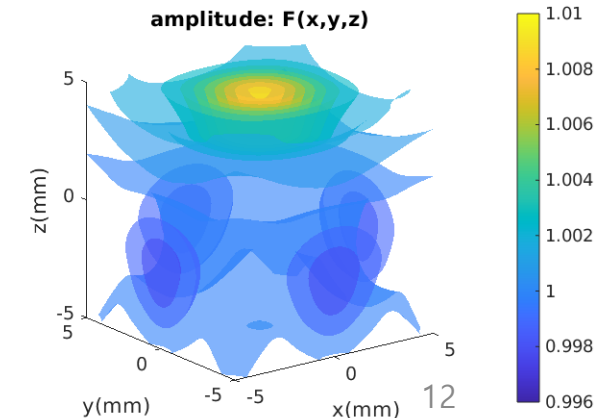
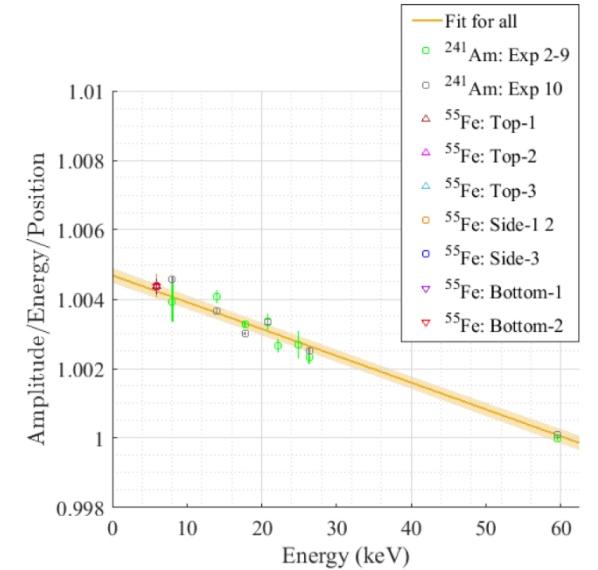

Exp.	Refrigerator	Calibration sources
1	DR	$^{55}\text{Fe}$ , $^{241}\text{Am}$ with Ag collimator
2–9	ADR	$^{55}\text{Fe}$ , $^{241}\text{Am}$ with Ag collimator
10	ADR	$^{55}\text{Fe}$ , $^{241}\text{Am}$ with Cu collimator
11 <sup>a</sup>	Calibration DR $\beta$ -spectrum DR	$^{55}\text{Fe}$ , (Ag, W) <sup>b</sup> $^{55}\text{Fe}$

<sup>a</sup> Exp. 11 was carried out after neutron activation.

<sup>b</sup> Characteristic X-rays of Ag and W could be activated from external  $\gamma$  sources during the calibration run.

# LiFE-SNS Phase1: two setups (After neutron activation)

- The setups are attached to a dry DR surrounded by a Pb shield at the Daejeon IBS HQ lab. (Above-ground) **T=23mK**
- Two detector modules: LiF(<sup>3</sup>H) + MMC with 30 Bq and 39 Bq
- Two-stage temperature control system with  $\Delta T_{rms} \sim 0.5 \mu\text{K}$
- An internal <sup>55</sup>Fe source is employed on each crystal.
- Data taking period: May~Dec/2024

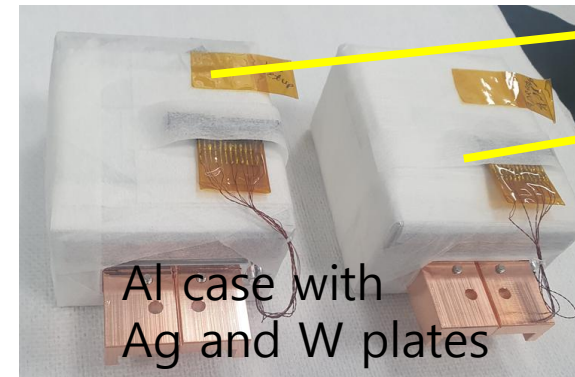
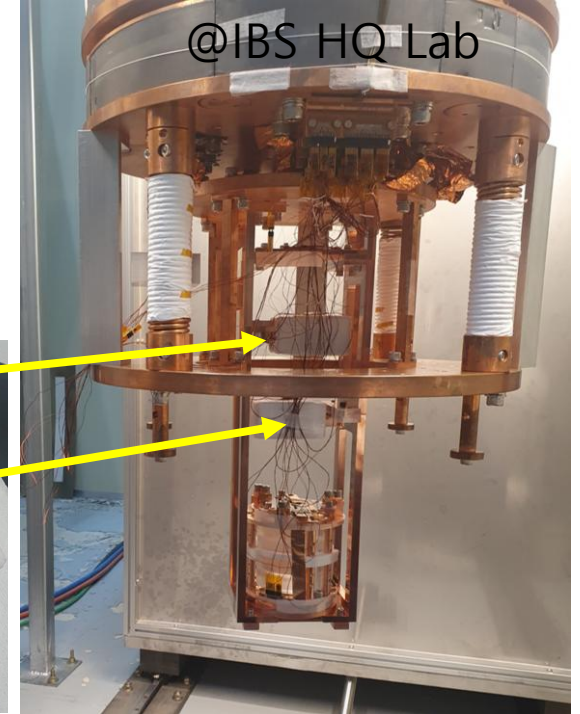

Two weeks calibration run with <sup>3</sup>H in LiF

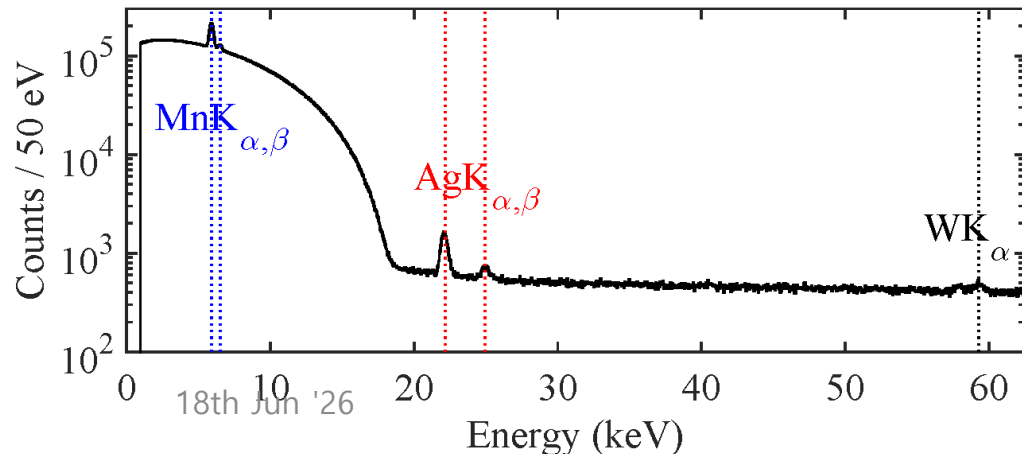

- After neutron irradiation, internal <sup>55</sup>Fe + X-ray fluorescence
- Metal plates of (Ag, W on s.c. shield)
  - Activated by external gamma sources
  - <sup>55</sup>Fe(5.9, 6.5 keV): On
  - Ag(22 keV, 25 keV), W(59 keV), Pb(75 keV): On and Off

# Energy calibration result (**After** neutron activation)

Position dependence correction

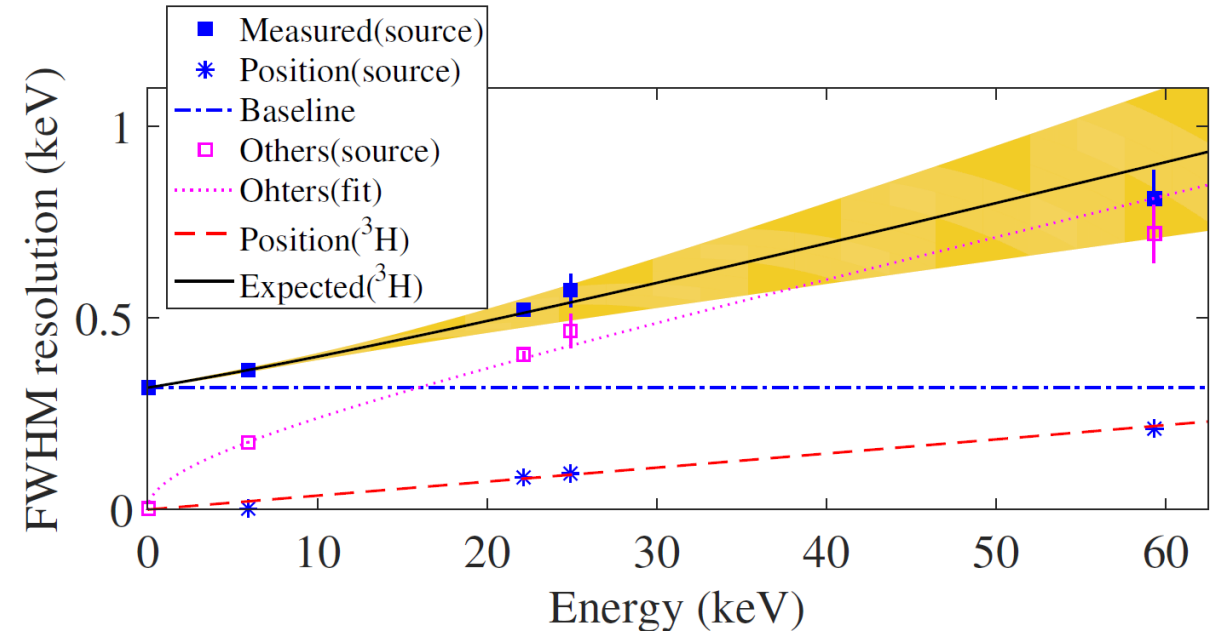
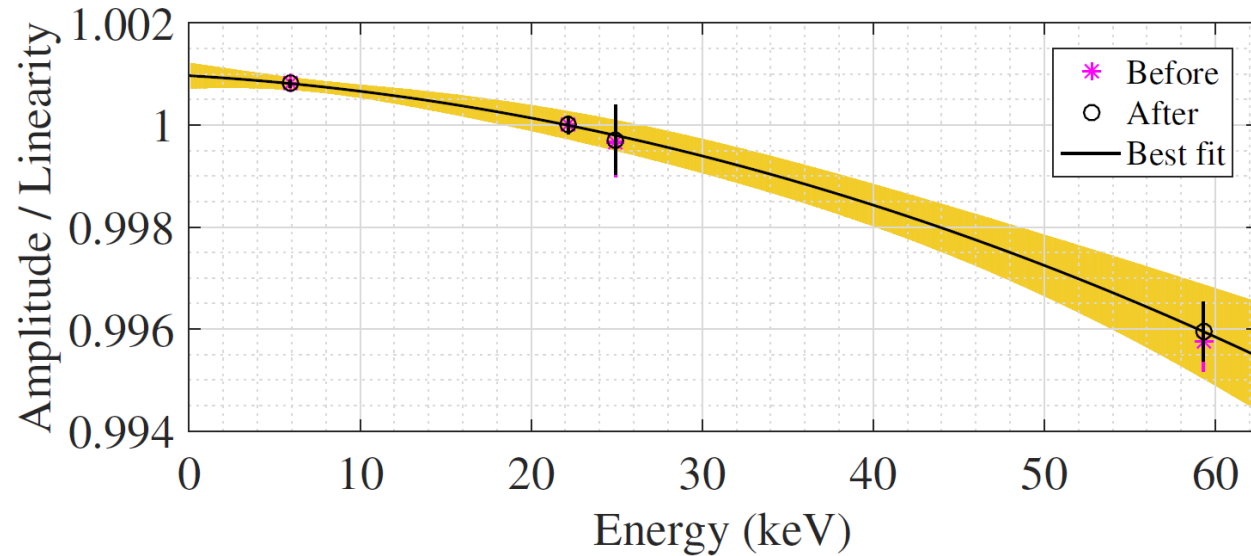

- Reasonable linearity and resolution are found.
- The calibration with the position correction function works for calibration lines.
- The uncertainties of the calibration curve and the resolution curve were incorporated as systematic errors.

# Theoretical $^3\text{H}$ spectrum

3eV @ endpoint

- ✓ **Energy deposit in LiF:**  $E_{\text{deposit}} = E_{\beta^-} + E_{\text{Recoil}} + E_{\text{Deexcitation}} + E_{\text{neutralization}} = Q - E_{\nu}$   
24.5873(1+), 79.0052(2+)  
eV
- ✓ Theoretical expectations are well-studied.

- **Relativistic**  $^3\text{H}$   $\beta$  spectrum including V-A, Weak magnetism current

$$M = \frac{G_F V_{ud}}{\sqrt{2}} \bar{u}(P_e) \gamma_\alpha (1 - \gamma_5) v(P_\nu) \bar{u}(p_f) \left[ G_V(q^2) + \frac{iG_M(q^2)}{2M_N} \sigma^{\alpha\beta} q_\beta - G_A(q^2) \gamma^\alpha \gamma_5 \right] u(p_i)$$

- Fermi function, Recoiled coulomb potential, Finite nuclear size correction, Screened Coulomb correction
- Radiative correction
- Spectral shape is determined by initial and final **atomic states**  
Transition probability accounting for exchange effect between  $\beta^-$  and electron (bound).



Refs: PRC 77, 055502 (2008), PRC 76, 045501 (2007), JCAP08(2014)038, JHEP 2016, 40 (2016), RMP. 90, 015008 (2018), JCAP02(2015)020, JHEP 2023, 144 (2023)

# $^3\text{H}$ $\beta$ decay spectrum fit: Using 10 days of one channel

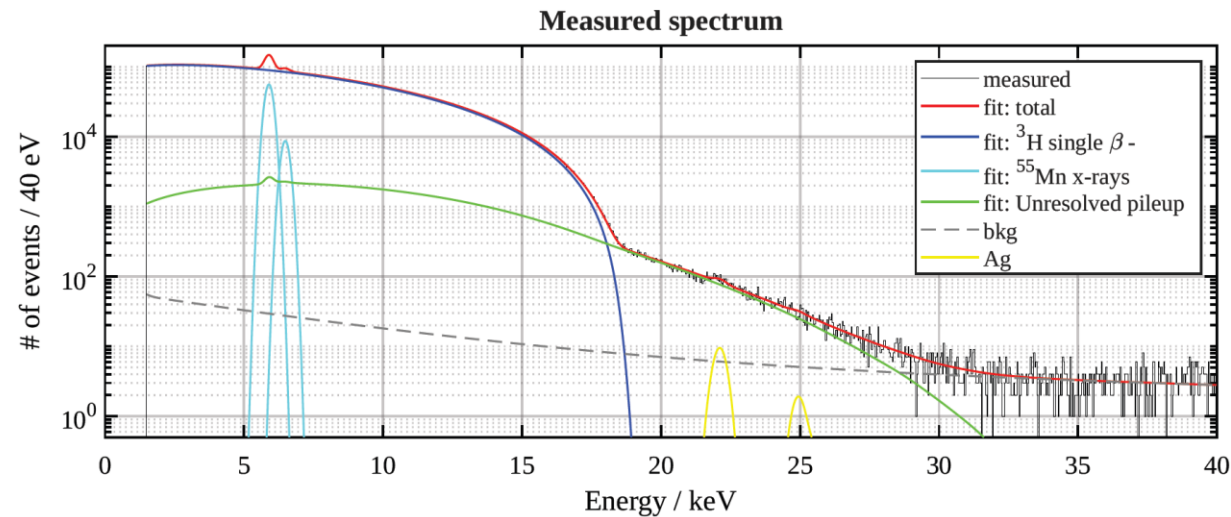

Null hypothesis

$\chi^2/\text{NDF} = 991.43/953$  in the range 1.5~40 keV

➔ Good agreement between the measured and expected values.

➔ We can activate the routine for sterile branch search.

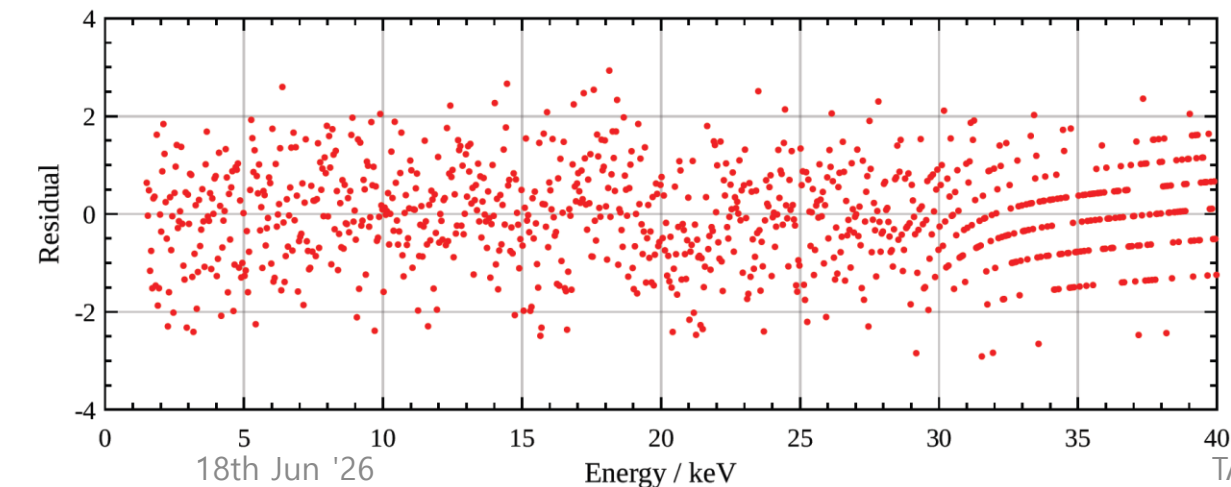

We included

- $^3\text{H}$  distribution in the LiF crystal
- Position calibration function
- One channel 10-day data  
(~1/20 of the measured data)

# Systematic Uncertainty

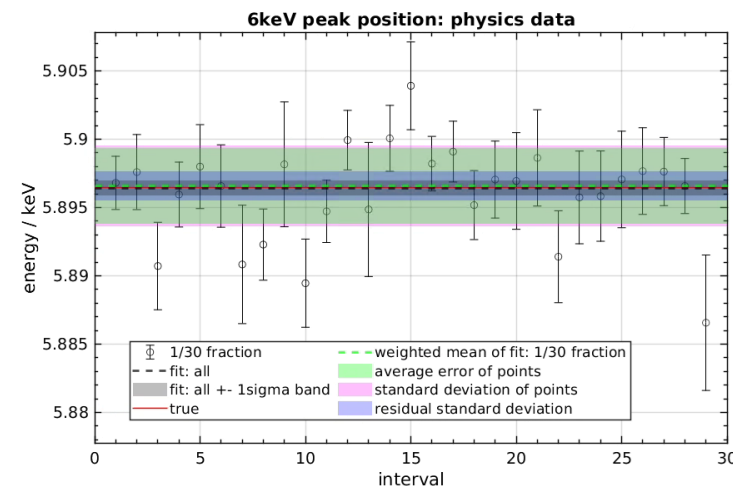
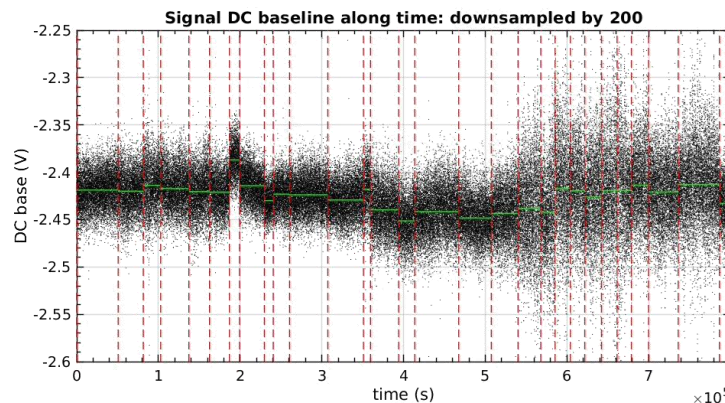
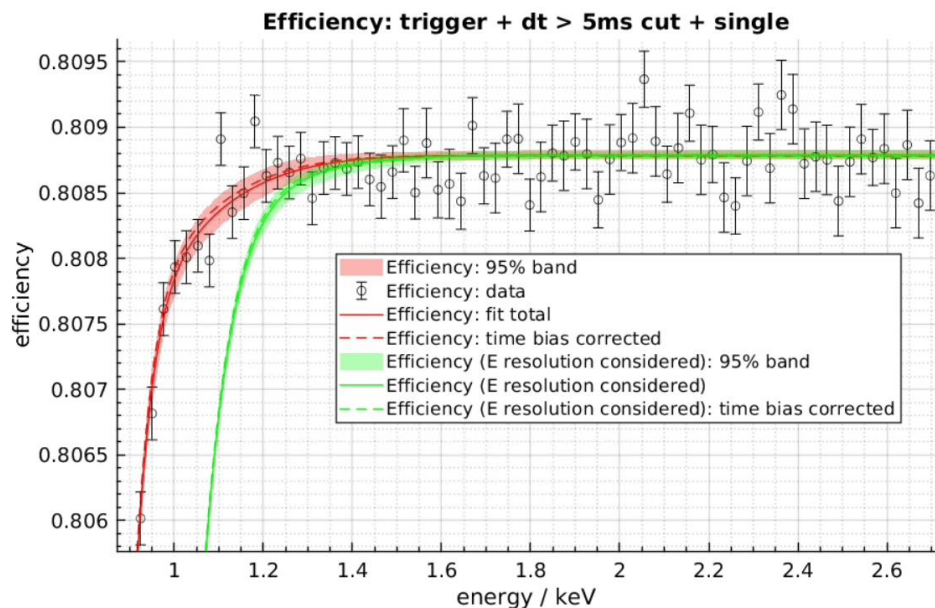

- Scaled templates are injected into the real data stream, and the fraction that passes the same data processing pipeline as the real data is evaluated.
- Negligible deviation from flatness above 1.5keV ( Total 45 ppm deviation @ 1.5keV region )

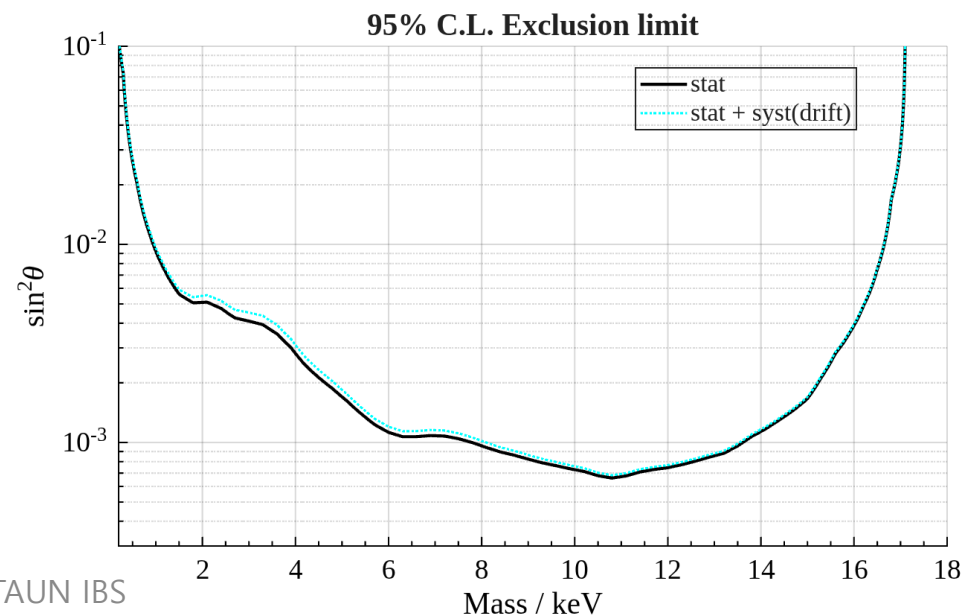

### 3. Uncertainty in energy calibration

- The calibration curve, modeled as a third-order polynomial constrained to pass through the origin, is constructed from four calibration points. Its uncertainty arises from the limited number of points (four, corresponding to two degrees of freedom) as well as the statistical uncertainties of each point.
- A bootstrap method, taken as a conservative approach, is applied to generate random realizations of the energy calibration curve and to evaluate the resulting distortions in the spectrum.
- Most of the spectral distortion is captured by four PCA components.

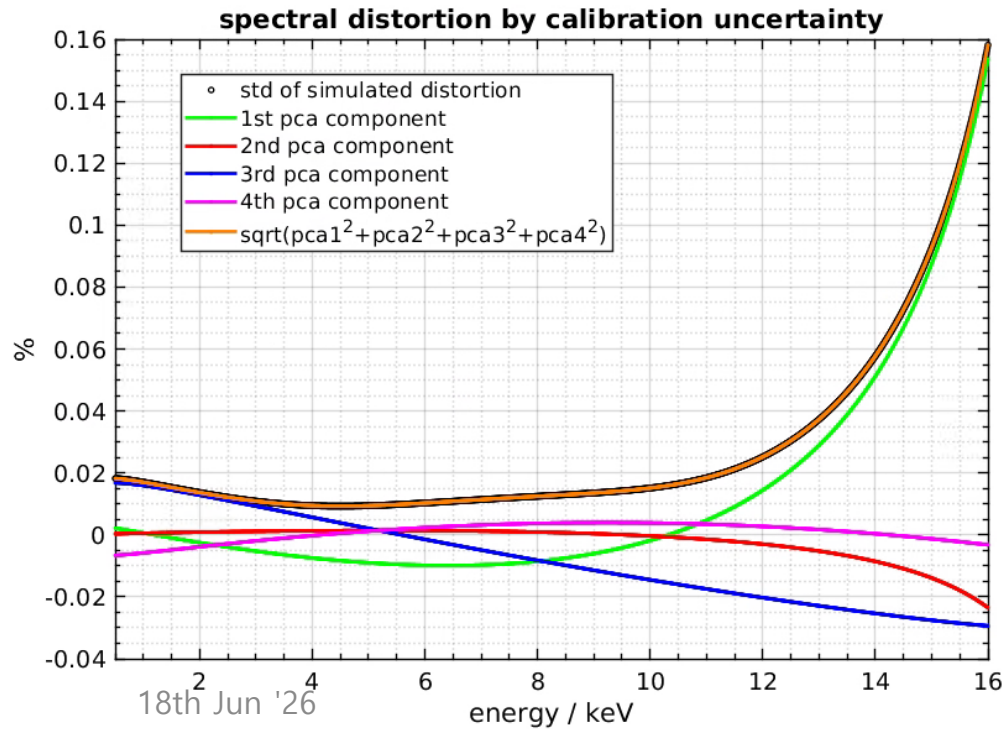
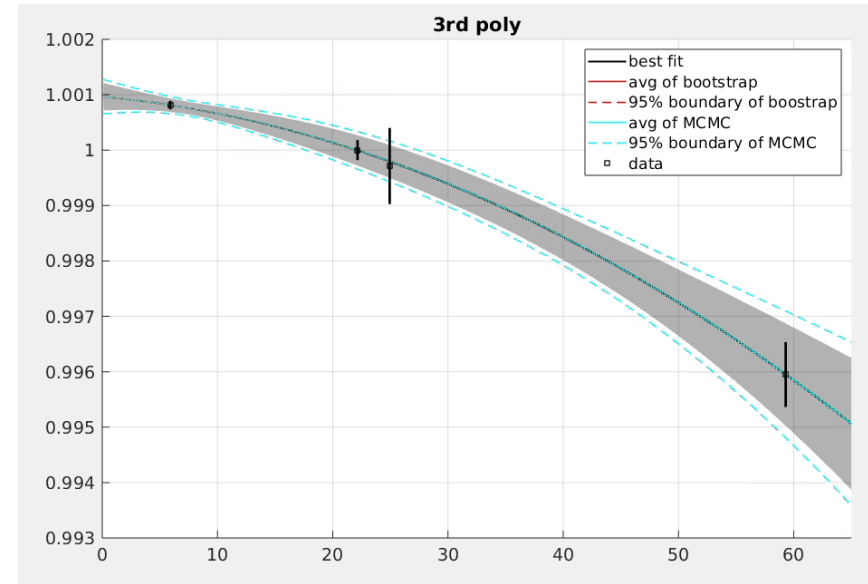

- In the statistical-only fit, the null model provides the best fit.
- When this systematic is included, a global minimum appears at 3.5 keV; however, the improvement over the null model is not significant ( $\Delta\chi^2 \approx -1$ ).

TAUN IBS

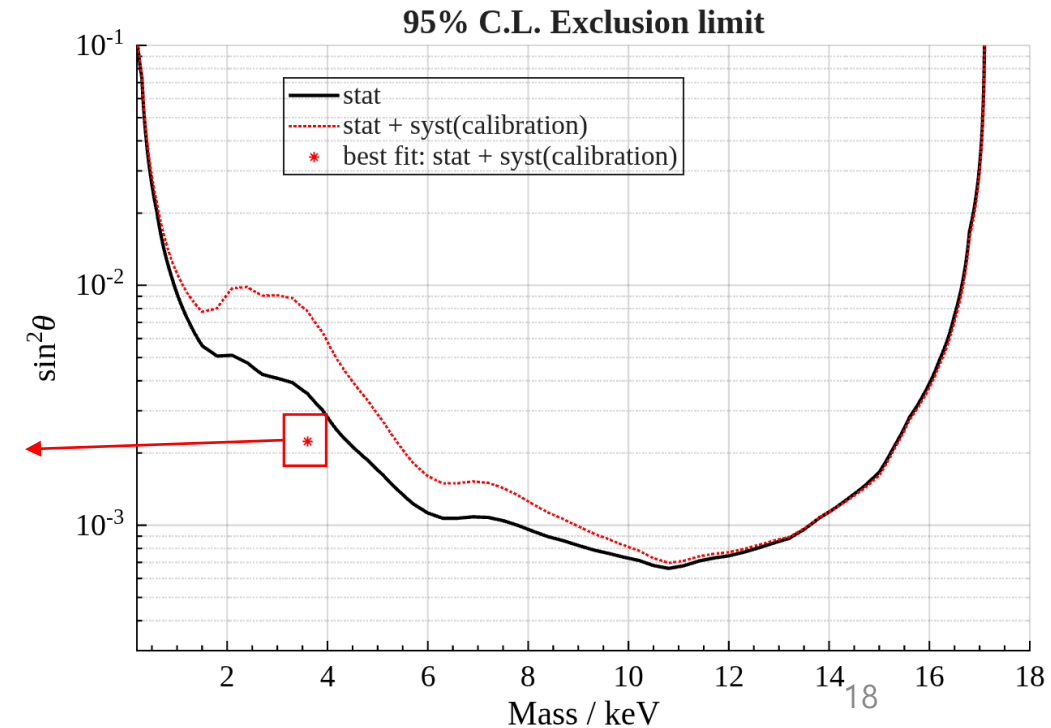

# Exclusion limit with 1-ch 10-day data

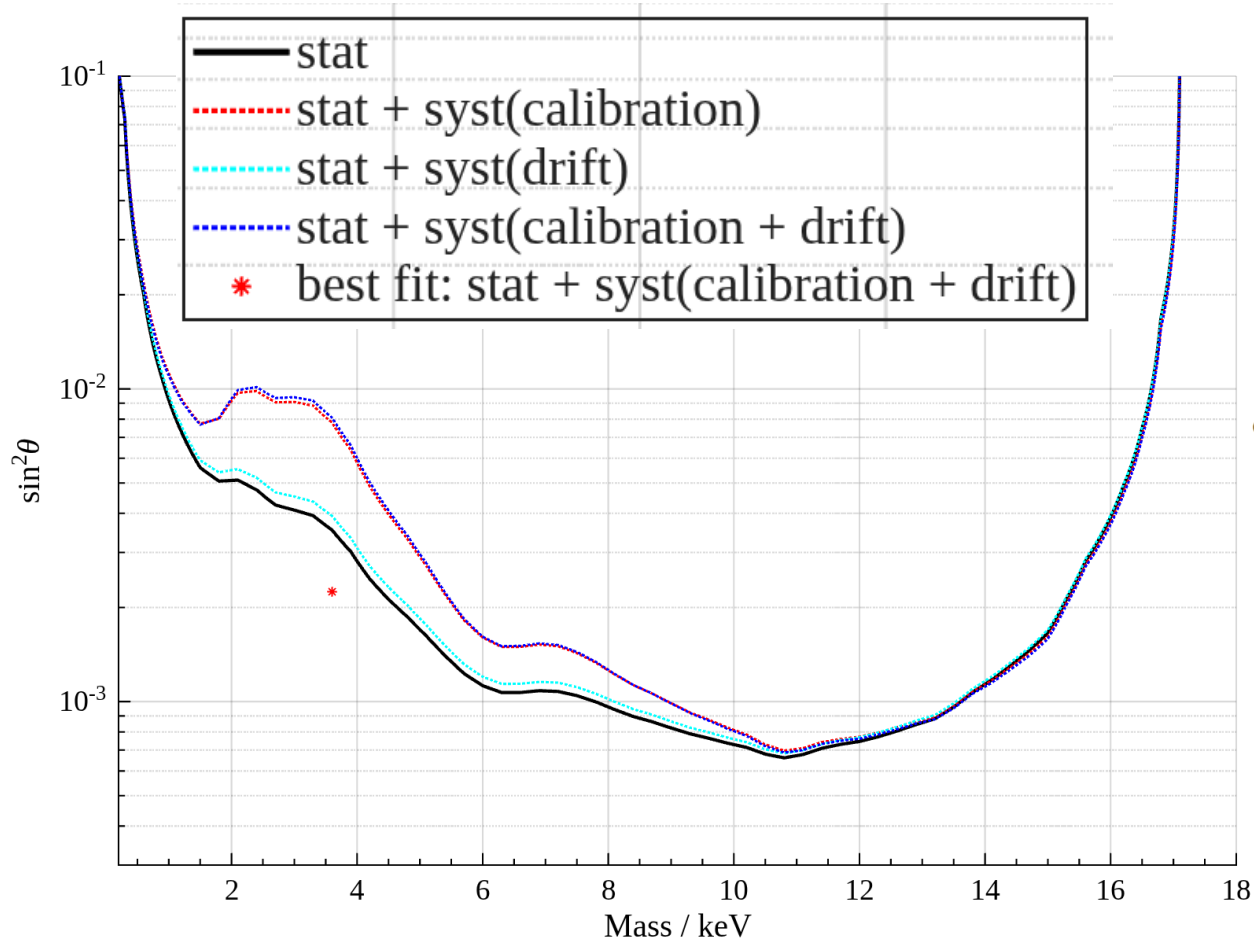

18th Jun '26

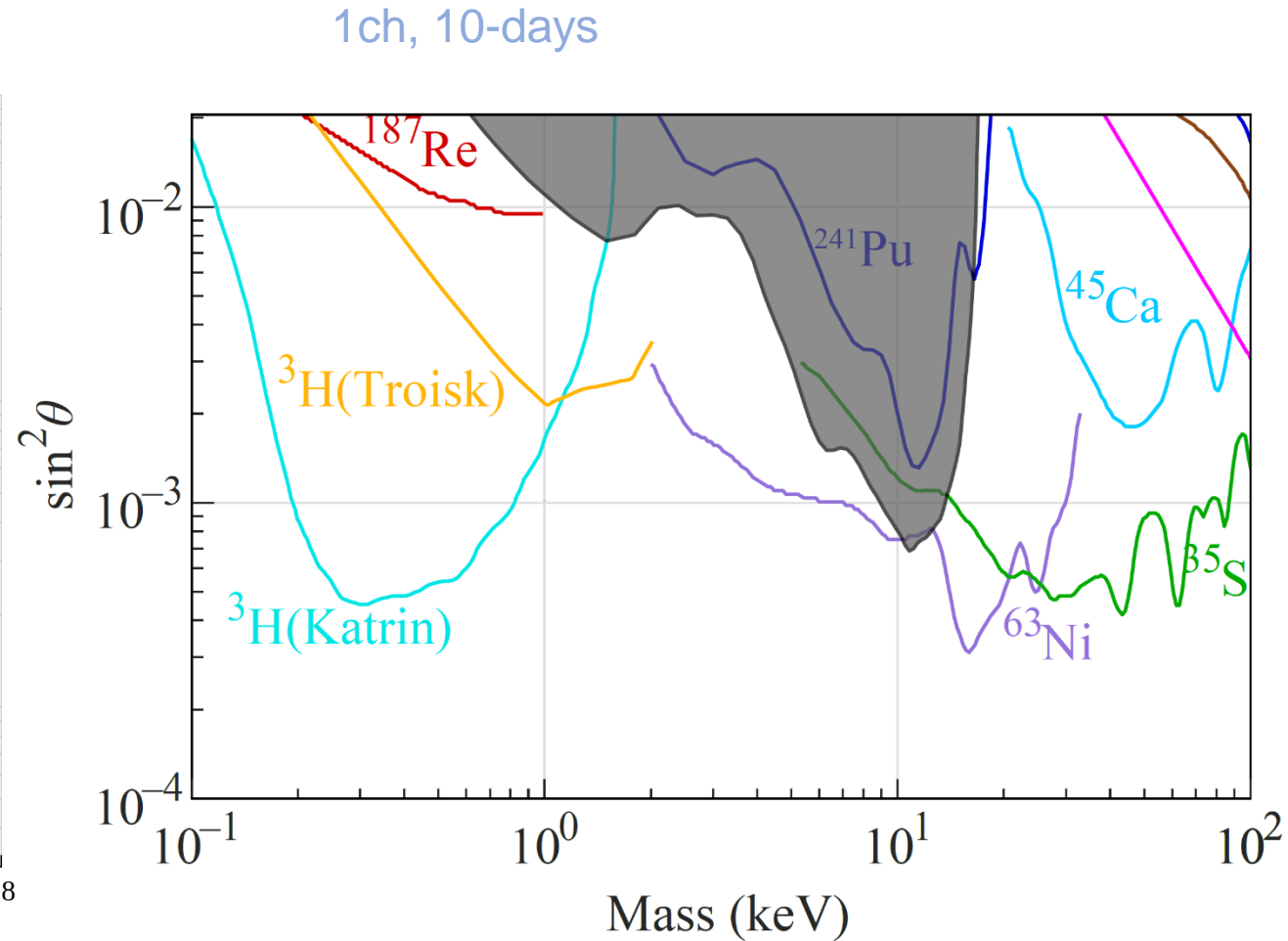

TAUN IBS

19

# General Neutrino Interaction

- Actually, sterile neutrino is one of GNI.

$$\mathcal{L}_{\text{GNI}}^{\text{CC}} = -\frac{G_F V_{\gamma\delta}}{\sqrt{2}} \sum_{j=1}^{10} \left( \overset{\text{CKM matrix (mixing between quarks)}}{\tilde{\epsilon}}_{j,\text{ud}} \right)^{\alpha\beta\gamma\delta} (\bar{e}_\alpha \mathcal{O}_j \nu_\beta) (\bar{u}_\gamma \mathcal{O}'_j d_\delta) + \text{H.c.}, \quad (\text{under Lorentz invariant})$$

↖ CKM matrix (mixing between quarks)  
↗ Flavour index with PMNS matrix (neutrino mixing)

- If there is no mixing,

$$: -\frac{G_F}{\sqrt{2}} \left( (g_V^2 + 3g_A^2) + \sum \epsilon_j (\bar{e} \mathcal{O}_j \nu) (\bar{u} \mathcal{O}'_j d) \right) + h.c.$$

- For other experiment  $\epsilon \sim 10^{-3}$ , so if our sensitivity for mixing angle  $\sim 10^{-3}$ , we can test further BSM parameters.

KATRIN PRL134, 251801 (2025)

$j$	$e_j$	$\mathcal{O}_j$	$\mathcal{O}'_j$
1	$\epsilon_L$	$\gamma_\mu(1 - \gamma^5)$	$\gamma^\mu(1 - \gamma^5)$
2	$\tilde{\epsilon}_L$	$\gamma_\mu(1 + \gamma^5)$	$\gamma^\mu(1 - \gamma^5)$
3	$\epsilon_R$	$\gamma_\mu(1 - \gamma^5)$	$\gamma^\mu(1 + \gamma^5)$
4	$\tilde{\epsilon}_R$	$\gamma_\mu(1 + \gamma^5)$	$\gamma^\mu(1 + \gamma^5)$
5	$\epsilon_S$	$(1 - \gamma^5)$	1
6	$\tilde{\epsilon}_S$	$(1 + \gamma^5)$	1
7	$-\epsilon_P$	$(1 - \gamma^5)$	$\gamma^5$
8	$-\tilde{\epsilon}_P$	$(1 + \gamma^5)$	$\gamma^5$
9	$\epsilon_T$	$\sigma_{\mu\nu}(1 - \gamma^5)$	$\sigma^{\mu\nu}(1 - \gamma^5)$
10	$\tilde{\epsilon}_T$	$\sigma_{\mu\nu}(1 + \gamma^5)$	$\sigma^{\mu\nu}(1 + \gamma^5)$

# GNI terms

$$\left(\frac{d\Gamma}{dE}\right)_j = \frac{G_F^2 V_{ud}^2}{2\pi^3} \sqrt{(E + m_e)^2 - m_e^2} \\ (E + m_e)(E_0 - E) \sqrt{(E_0 - E)^2 - m_j^2} \\ \xi \left[ \boxed{1 + b \frac{m_e}{E + m_e}} - b' \frac{m_j}{E_0 - E} - c \frac{m_e m_j}{(E + m_e)(E_0 - E)} \right] \\ \sim 1 \quad \sim -(b' + c) * \frac{m_N}{E_\nu} \rightarrow -b' \frac{m_N}{E_\nu}$$

- $\xi$  : Normalization like mixing angle
- $b' m_N / E_\nu$   
: Distortion of energy spectrum  
: Heavy mass induces large distortion

For  $N$  instead of  $\beta$ ,  $U \rightarrow S$ ,  $T \rightarrow V$

SM model  $\rightarrow$

$$\xi_\beta = |U_{ei}|^2 [(g_V^2 + 3g_A^2)(1 + |\epsilon_L|^2 + |\epsilon_R|^2 + 2\text{Re}(\epsilon_L)) \\ + 2(g_V^2 - 3g_A^2)(\text{Re}(\epsilon_R \epsilon_L^*) + \text{Re}(\epsilon_R)) + g_S^2 |\epsilon_S|^2 \\ + 48g_T^2 |\epsilon_T|^2] + |T_{ei}|^2 [(g_V^2 + 3g_A^2)(|\tilde{\epsilon}_L|^2 + |\tilde{\epsilon}_R|^2) \\ + 2(g_V^2 - 3g_A^2)\text{Re}(\tilde{\epsilon}_R \tilde{\epsilon}_L^*) + g_S^2 |\tilde{\epsilon}_S|^2 + 48g_T^2 |\tilde{\epsilon}_T|^2],$$

$$\xi_\beta b_\beta = |U_{ei}|^2 [2g_S g_V \text{Re}(\epsilon_S (1 + \epsilon_L + \epsilon_R)^*) \\ - 24g_A g_T \text{Re}(\epsilon_T (1 + \epsilon_L - \epsilon_R)^*)] + |T_{ei}|^2 [2g_S g_V \\ \text{Re}(\tilde{\epsilon}_S (\tilde{\epsilon}_L + \tilde{\epsilon}_R)^*) + 24g_A g_T \text{Re}(\tilde{\epsilon}_T (\tilde{\epsilon}_L - \tilde{\epsilon}_R)^*)]$$

$$\xi_\beta b'_\beta = \text{Re}(U_{ei} T_{ei}) [2g_V g_S \{ \text{Re}(\tilde{\epsilon}_S (1 + \epsilon_L + \epsilon_R)^*) \\ + \text{Re}(\epsilon_S (\tilde{\epsilon}_L + \tilde{\epsilon}_R)^*) \} \\ - 24g_A g_T \{ \text{Re}(\tilde{\epsilon}_T (1 + \epsilon_L - \epsilon_R)^*) \\ - \text{Re}(\epsilon_T (\tilde{\epsilon}_L - \tilde{\epsilon}_R)^*) \}],$$

$$\xi_\beta c_\beta = \text{Re}(U_{ei} T_{ei}) [2g_V^2 \text{Re}((\tilde{\epsilon}_L + \tilde{\epsilon}_R)(1 + \epsilon_L + \epsilon_R)^*) \\ - 6g_A^2 \text{Re}((\tilde{\epsilon}_L - \tilde{\epsilon}_R)(1 + \epsilon_L - \epsilon_R)^*) \\ + 2g_S^2 \text{Re}(\epsilon_S \tilde{\epsilon}_S^*) + 96g_T^2 \text{Re}(\epsilon_T \tilde{\epsilon}_T^*)].$$

# Tritium beta spectrum

$$\frac{d\Gamma}{dE} = \frac{G_F^2 V_{ud}^2}{2\pi^3} F(E, 2) \sqrt{(E + m_e)^2 - m_e^2} (E + m_e) \cdot \sum_j \sum_{k=\beta, N} \zeta_j \varepsilon_j \sqrt{\varepsilon_j^2 - m_k^2} \xi_k \left[ 1 - b'_k \frac{m_k}{\varepsilon_j} \right] \Theta(\varepsilon_j - m_k).$$

- Additional corrections : Relativistic Fermi function, Exchange effect, radiative correction, Recoiled Coulomb correction, Finite nuclear size correction, Screened Coulomb correction.
- $j$  stands for 30 atomic states (shake-up) and continuum state (shake-off)
- $\beta$  : electron neutrino,  $N$  : sterile neutrino
- GNI effect :  $\xi_{k=\beta, N}$  ,  $b_{k=\beta, N}'$

# Spectrum shape for $(m_N, b'_N)$

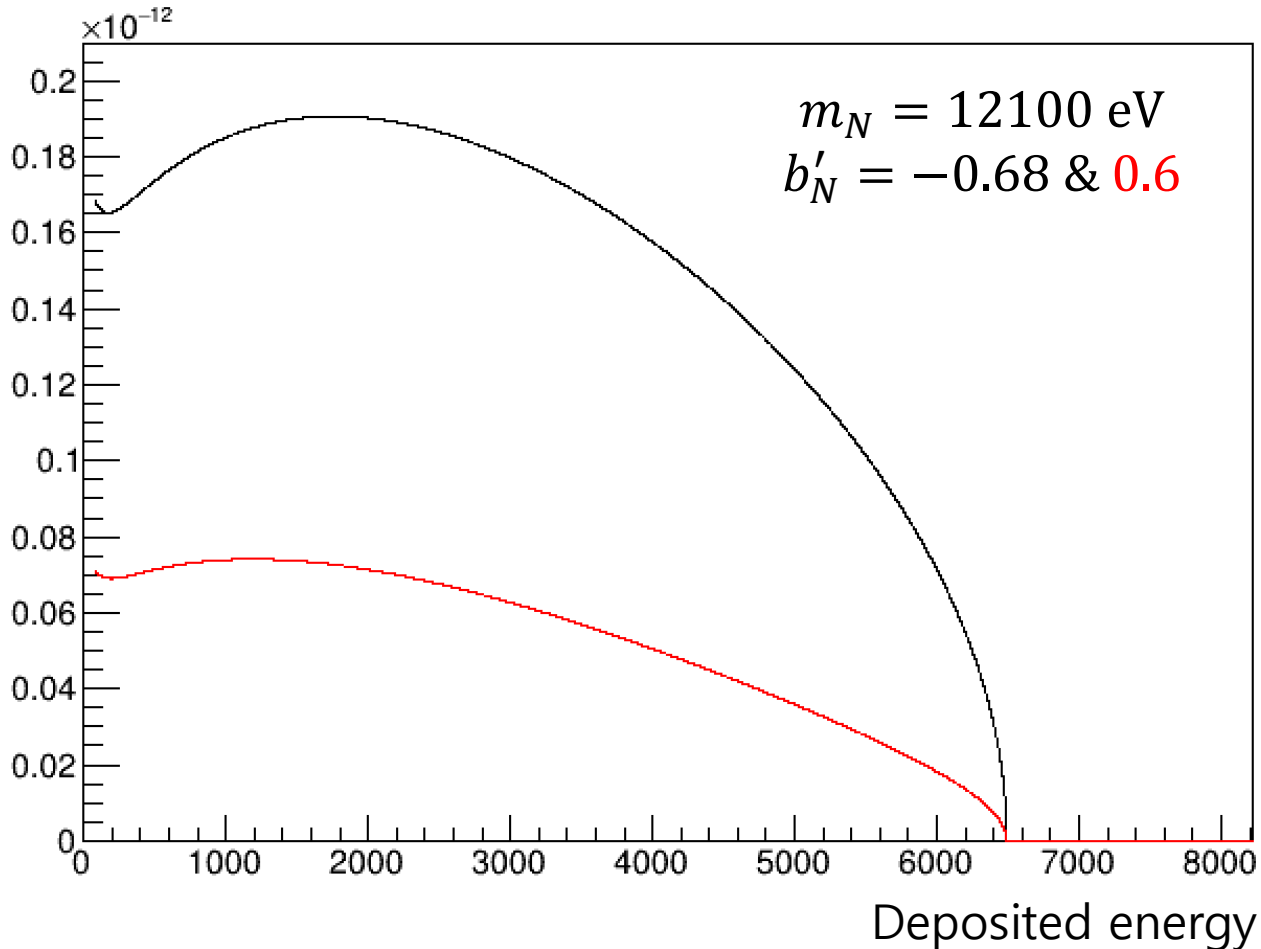

$$\frac{d\Gamma}{dE} = A(E, m_e) \sum_j \zeta_j \varepsilon_j \left( \sqrt{\varepsilon_j^2 - m_N^2} \zeta_N \left( 1 - b'_N \frac{m_N}{\varepsilon_j} \right) \right)$$

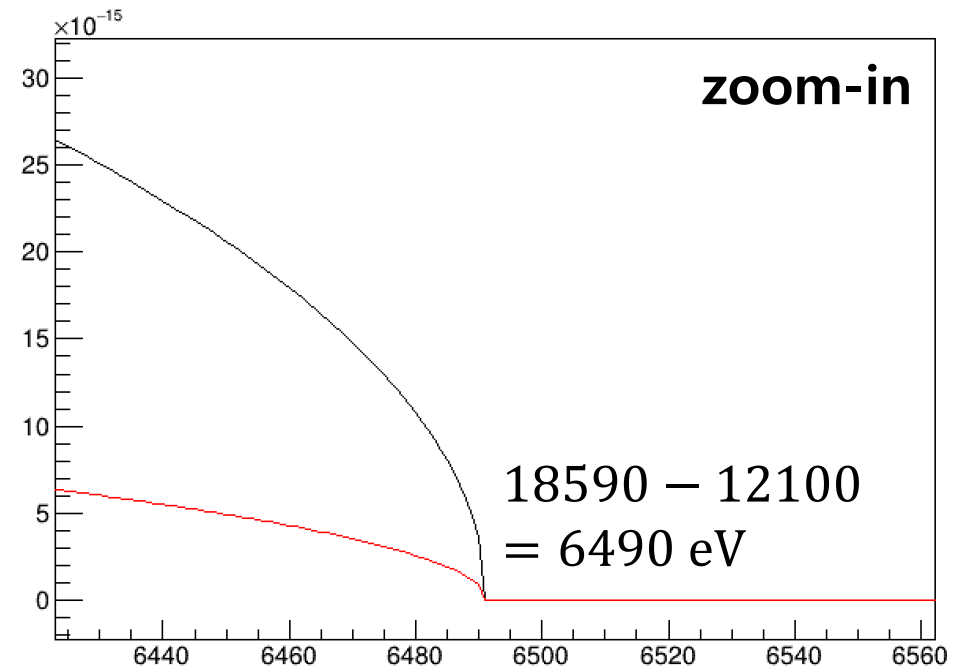

# Grid of parameters for sensitivity

- Parameters:  $\xi_\beta, b'_\beta, m_\beta = 0, \xi_N, b'_N, m_N$
- $\frac{d\Gamma}{dE} = A(E, m_e) \sum_j \zeta_j \varepsilon_j \left( \left( \sqrt{\varepsilon_j^2 - m_N^2} \xi_N (1 - b'_N \frac{m_N}{\varepsilon_j}) \right) + \left( \sqrt{\varepsilon_j^2 - m_\beta^2} \xi_\beta (1 - b'_\beta \frac{m_\beta}{\varepsilon_j}) \right) \right)$
- GNI effect  $\propto \xi_k$  and  $\xi_k b'_k m_k$
- For SM & sterile neutrino,
- $\xi_\beta \sim |U_{eN}|^2 (g_V^2 + 3g_A^2) (1 + |\epsilon_R^2|) \sim 5.79 (\pm 0.5\%)$  : fix
- $\xi_N \sim (g_V^2 + 3g_A^2) (|S_{eN}|^2 + |V_{eN}|^2 |\tilde{\epsilon}_L|^2)$ , leading term  $|S_{ei}|^2$  means mixing. : 201 in [5E-5, 10]
- $b'_N \sim |S_{eN}| |T_{eN}| \tilde{\epsilon}_{L,R,S,T} (1 + \tilde{\epsilon}_{L,R,S,T} \pm \tilde{\epsilon}_{L,R,S,T}) / \xi_N$  can varies  $-5 \sim 5$  : 101 in [-5,5]
- $m_N$  : 111 in [0,18590] eV (bin=169eV)

# Shape distortion of $b'$

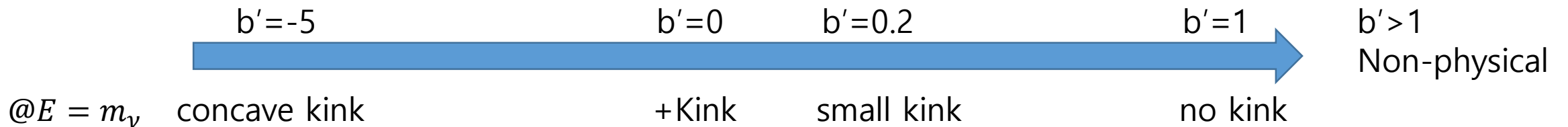
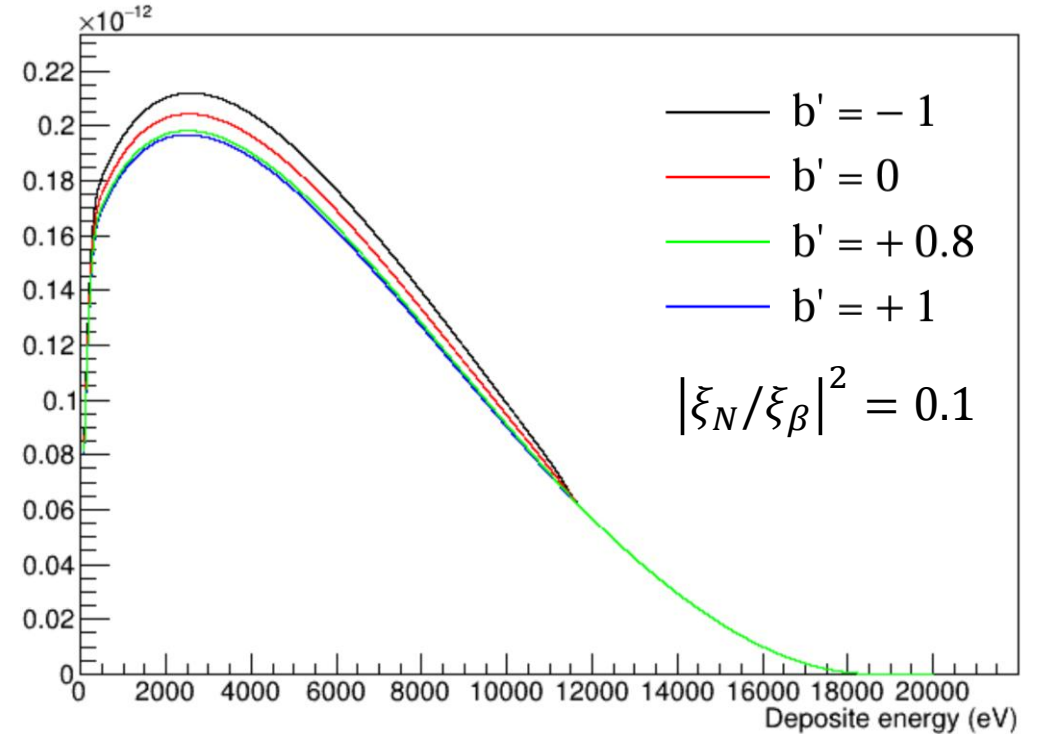
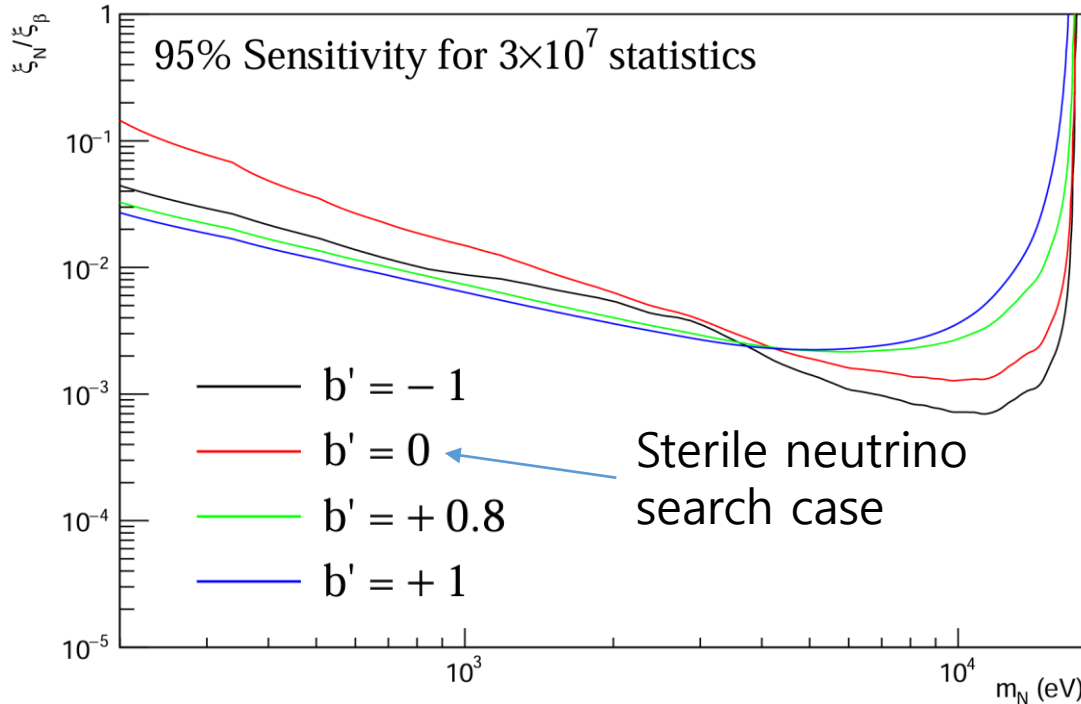

# Sensitivity and ROI for GNI effect

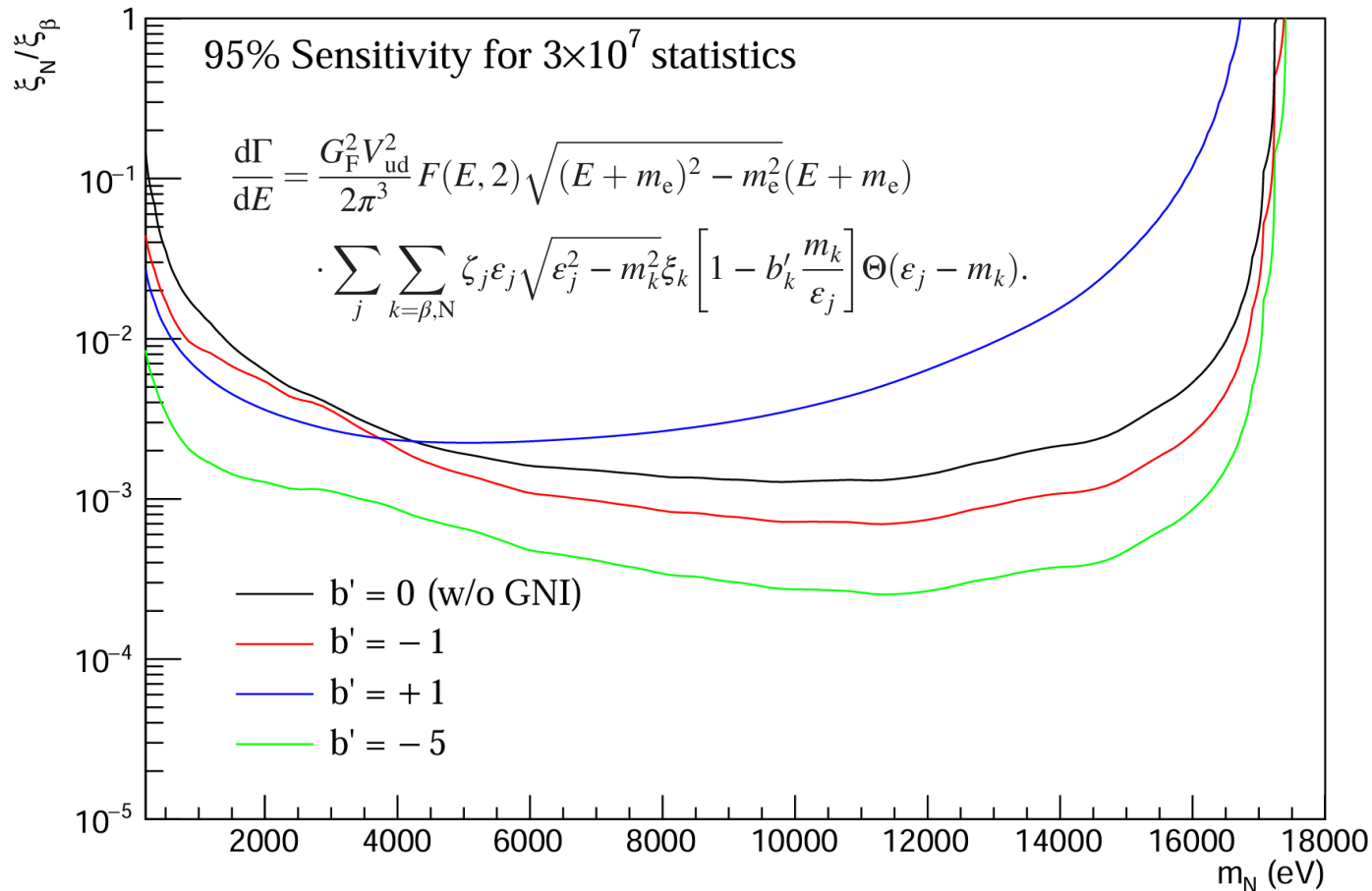

1.  $|S|^2$ : mixing between heavy mass and light mass state ( $< 0.001$ ,  $|V|^2 = 1 - |S|^2$ )
2.  $\tilde{\varepsilon}_S < 10^{-2}$
3.  $\tilde{\varepsilon}_T < 10^{-3}$  *PhysRevLett.134.251801*

Leading term (1<sup>st</sup> order of  $\varepsilon$ ,  $g_{V,A,S,T} = 1$ )  
 :  $b' = \frac{V}{S} * 2(\tilde{\varepsilon}_S - 12\tilde{\varepsilon}_T) > 60 * (\tilde{\varepsilon}_S - 12\tilde{\varepsilon}_T)$   
 if  $-\tilde{\varepsilon}_S + 12\tilde{\varepsilon}_T$  is enough large,  $b' = -5$

Most sensitive at  $m_N = 11\text{keV}$   
 for tritium beta spectrum

	$m_\nu < 4\text{keV}$	$4\text{keV} < m_\nu$
$b'$	-5~0	-5~1

# Sensitivity ( $\xi_N/\xi_\beta, b'_N$ ) for $m_N = 11\text{keV}$

- At  $m_\nu = 11\text{keV}$  for 2 cases  
:  $|S|^2 = 1 \times 10^{-3}, 1 \times 10^{-5}$
- For 95% sensitivity,  
 $\xi_N(b' = -5) = 2.93 \times 10^{-4}$   
 $\xi_N(b' = 1) = 4.69 \times 10^{-3}$
- Input values  
 $g_V = 1.0$  ,  $g_A/g_V = 1.2646$  ,  $g_S = 1.02$   
 $g_P = 349$  ,  $g_T = 1.02$

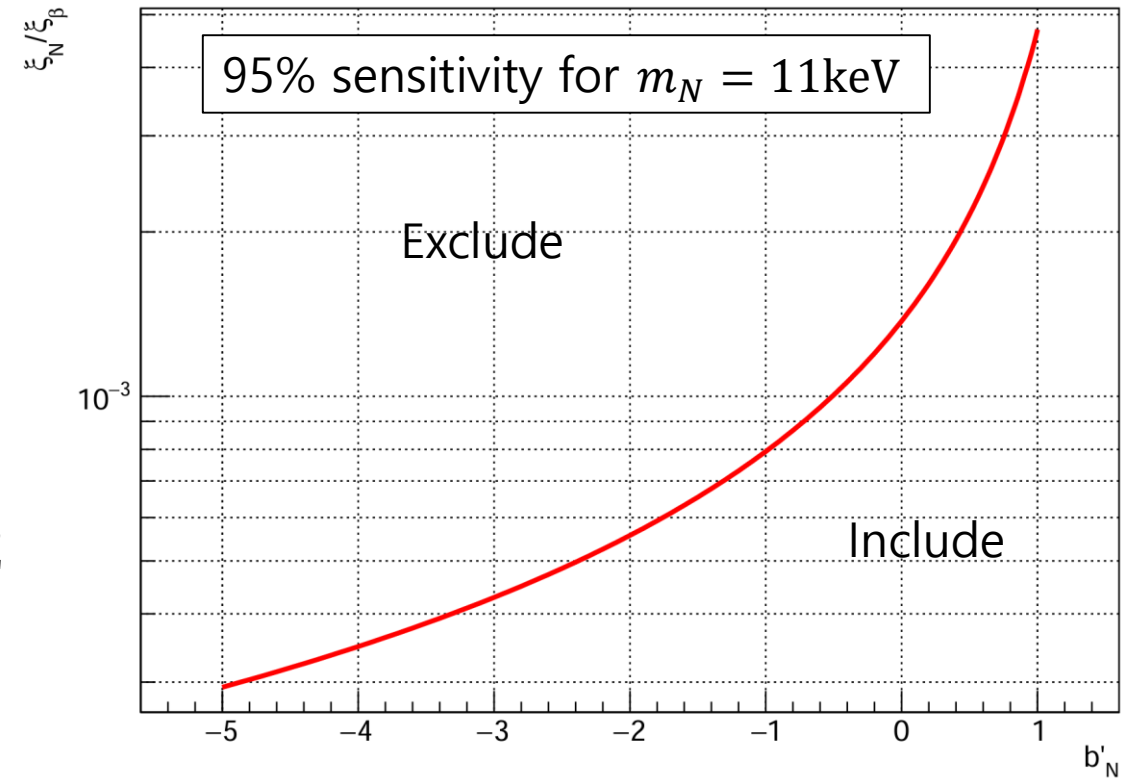

# Exclusion contours for $\epsilon_i$ and $\tilde{\epsilon}_j$

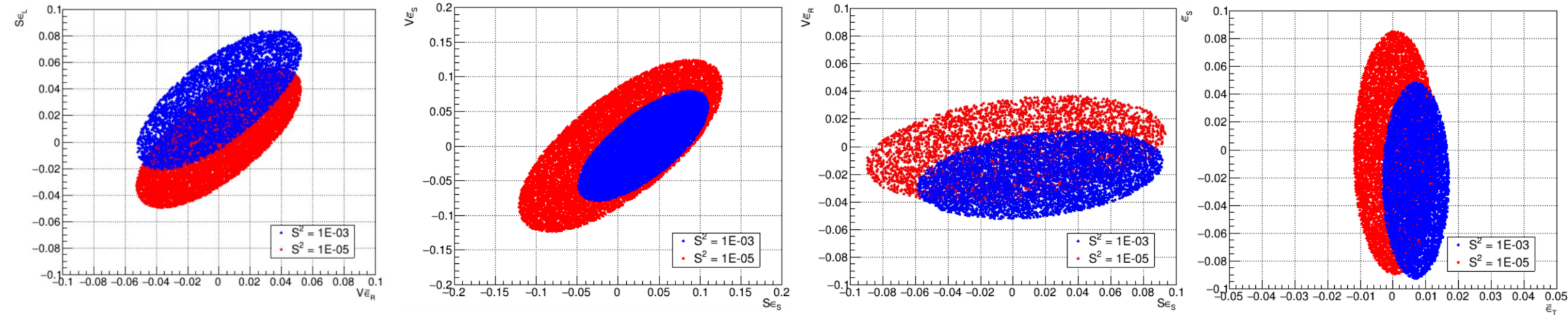

- $|\tilde{\epsilon}_R| < 0.04 \sim 0.052$   $|\tilde{\epsilon}_S| < 0.082 \sim 0.089$   $|\tilde{\epsilon}_T| < 0.013 \sim 0.016$
- Ref.) KATRIN  
 $|\tilde{\epsilon}_R| < 0.057 \sim 0.118$ ,  $|\tilde{\epsilon}_S| < 0.134 \sim 0.278$ ,  $|\tilde{\epsilon}_T| < 0.020 \sim 0.042$
- Full scan of tritium beta spectrum has benefit to constrain the bound.

# Summary

- For sterile neutrino search, we can reach lowest limit  $10^{-3}$  at 11keV mass using only 10 day data-set (1 crystal).
- For 4 month data-set(for 2crystal), we expect best limit in 2-18keV region.
- Based on the sensitivity for the null pseudo events, result for GNIs analysis is promising.
- We would make first result of GNI searching full range in tritium beta spectrum, 10-days statistics.

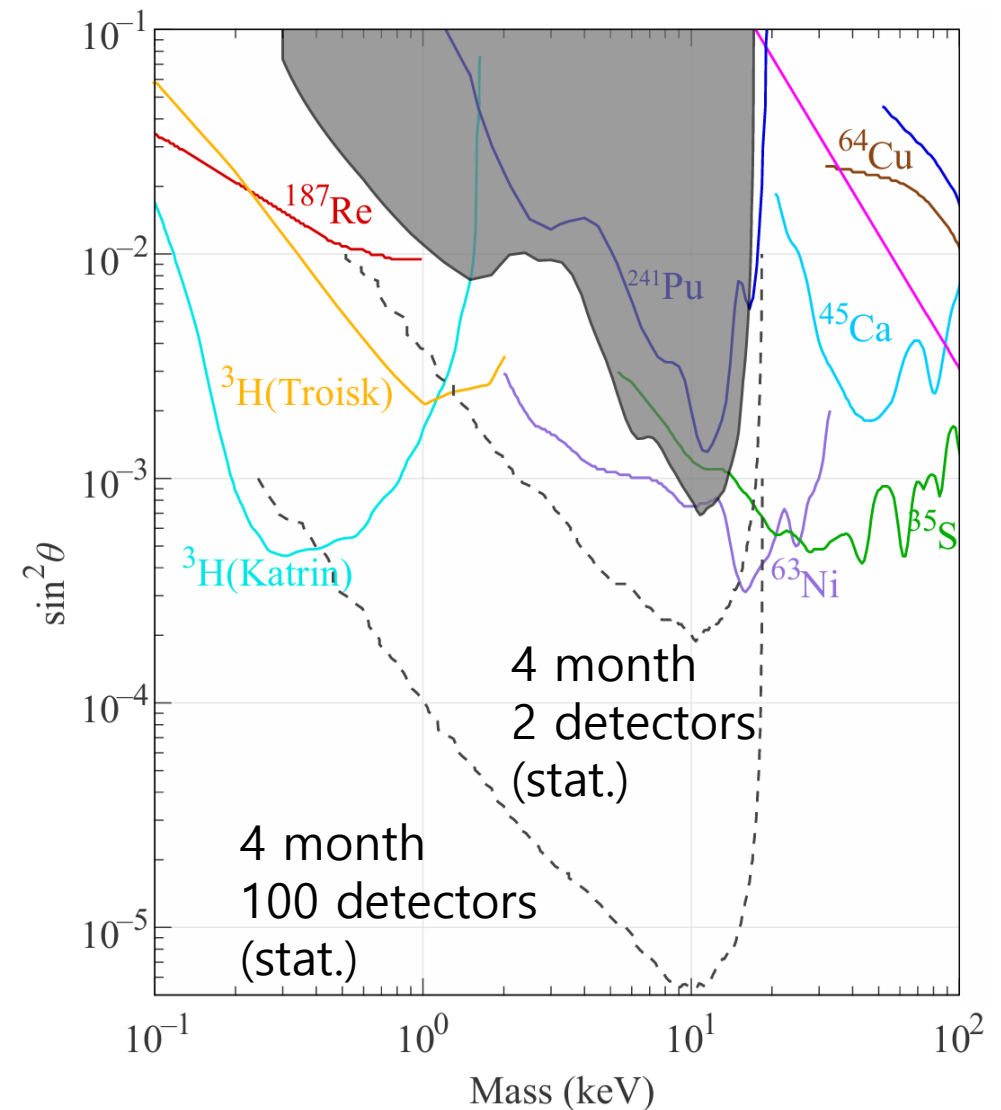



# Data processing

Relation to previous signal

width of previous signal

For continuous data

1. Applying frequency filter with band pass: [0.1kHz 1.5kHz]
2. Event trigger with DC trigger level(360eV) and 1ms dead time
3. Template fit to triggered event to calculate pulse amplitude
4. Event cut with 3 parameters:
  - 1. loose cut for width of previous signal &  $dt > 8\text{ms}$ ,
  - 2. Mean time cut

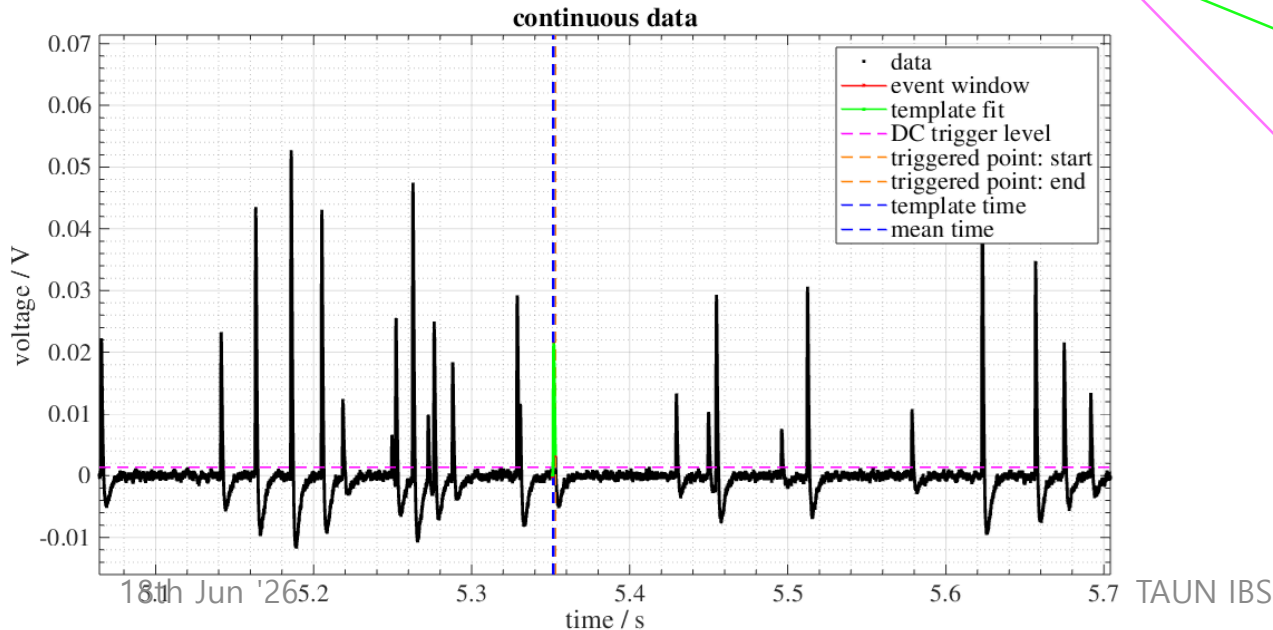
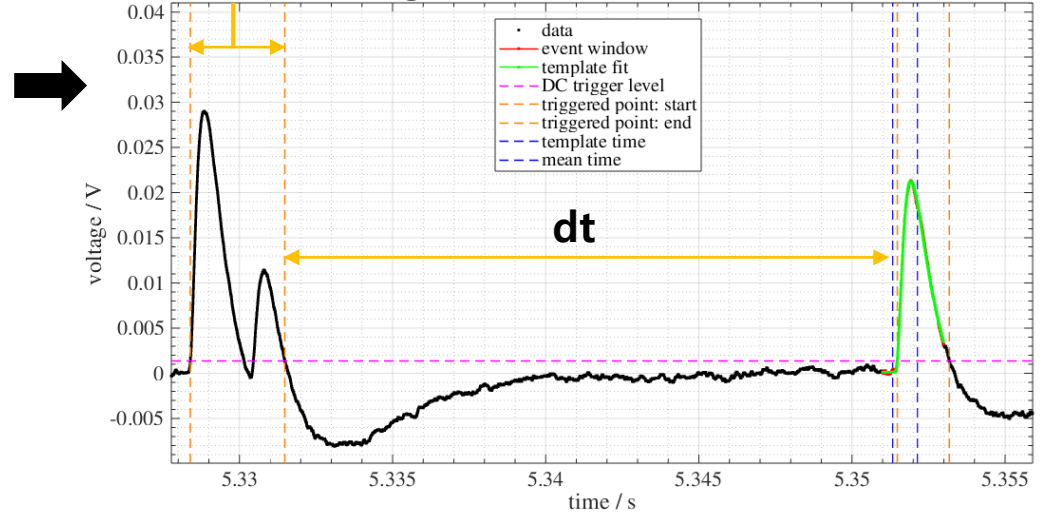

Mean time

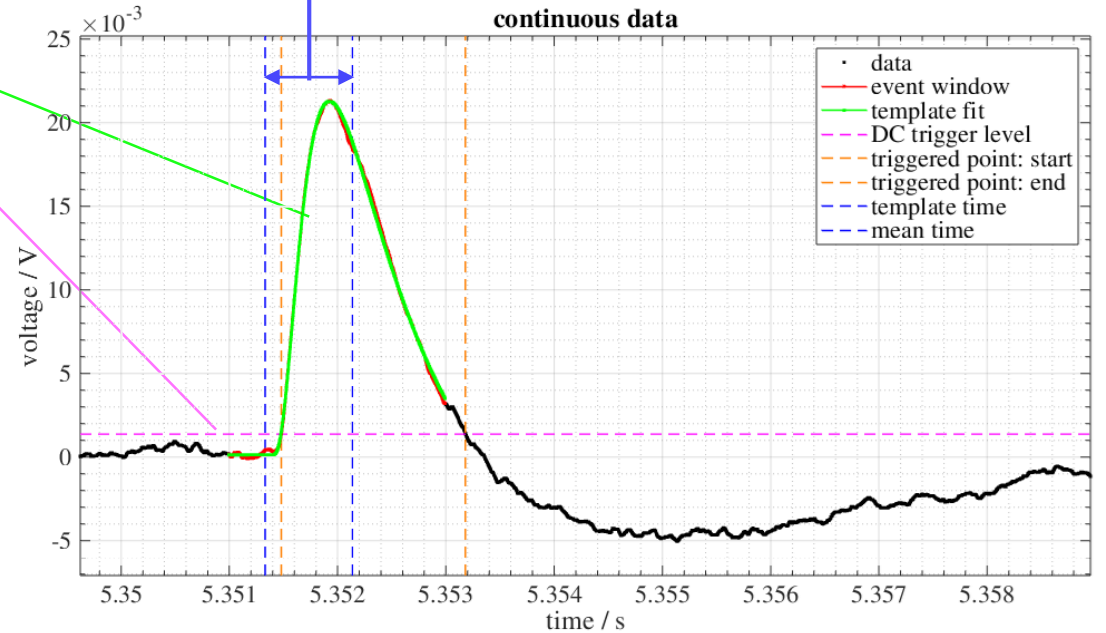

# Pseudo data

Make continuous pseudo data with long (~100ms) **signal template** and **noise** and **event rate** (3H, Mn 6keV peaks) from real data and expected energy spectrum of 3H decay

- Template is scaled along energy calibration
- Apply same trigger logic, event selection criteria as real data

## To calculate

- Efficiency estimation, **especially for single event**
- Bias correction in pulse amplitude for low energy signal
- Unresolved pileup spectrum

Expect spectrum  $T(E)$  to fit measured

$$T(E) = \int_{-\infty}^{\infty} (S(E')/\text{Eff}(E')) * R(E, E') dE' + D(E) + \text{bkg}(E)$$

- $S(E)$ : theoretical 3H spectrum,
- $\text{Eff}(E')$ : efficiency for single event,
- $R$ : detector resolution,
- $D(E)$ : Unresolved pileup spectrum
- $\text{bkg}(E)$ : background spectrum

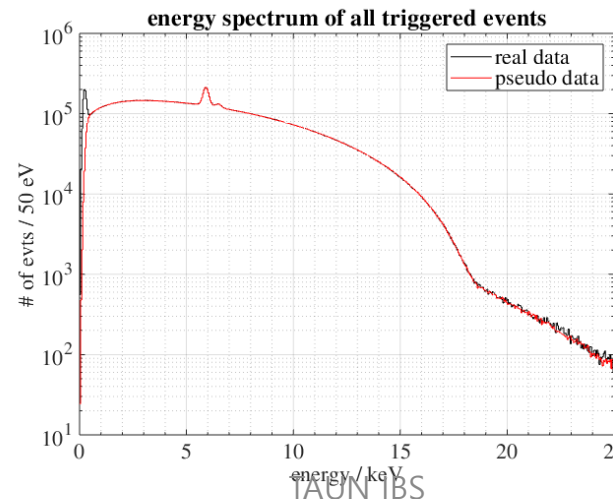

## Schematic of analysis flow

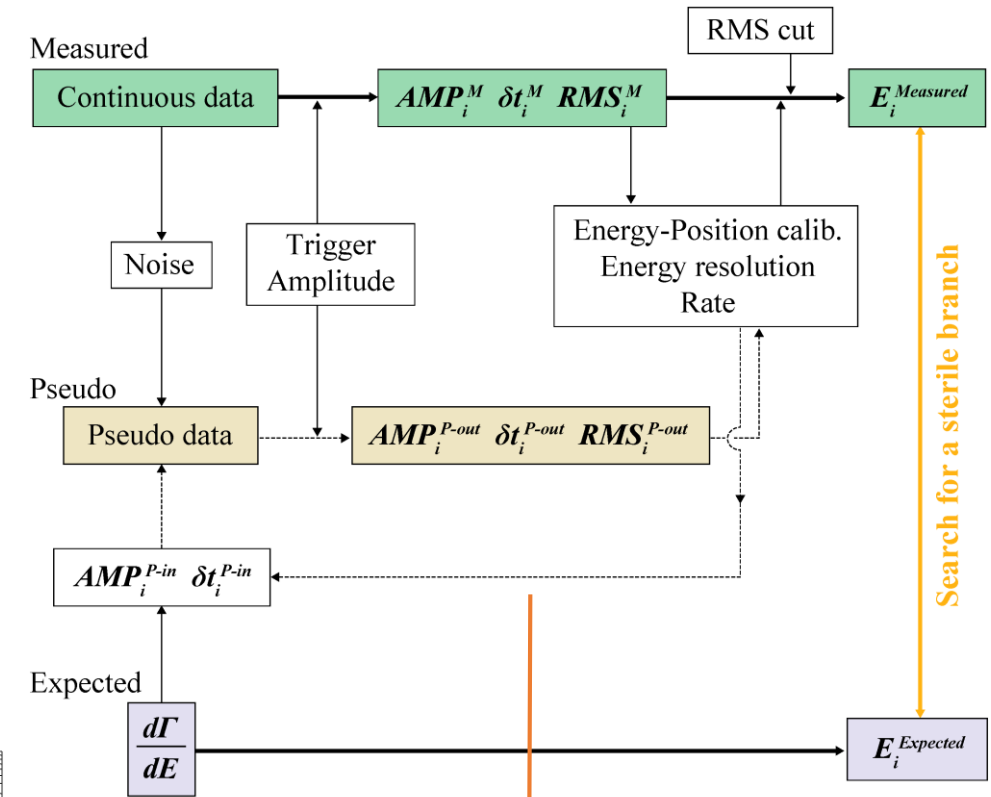

2-3 times iteration needed to saturate the value of event rate & bias correction